

Mounting hole patterns for most 29/30mm high cameras including AVT, Keyence, Omron, Point Grey, Sony, etc.

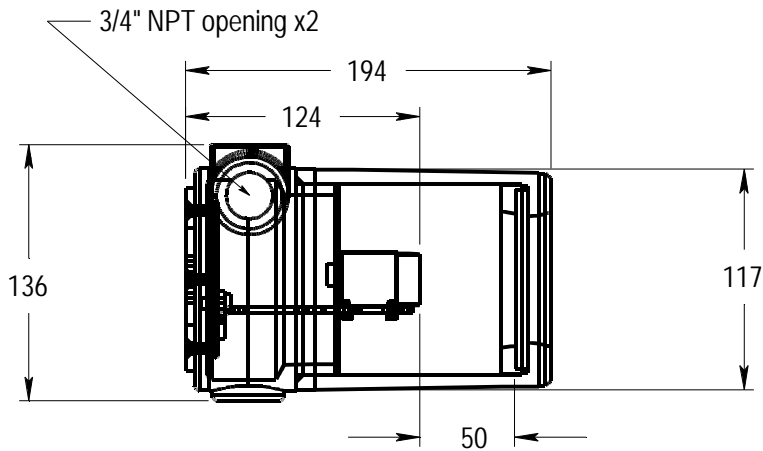

(4) M3 and (4) M2 fasteners included

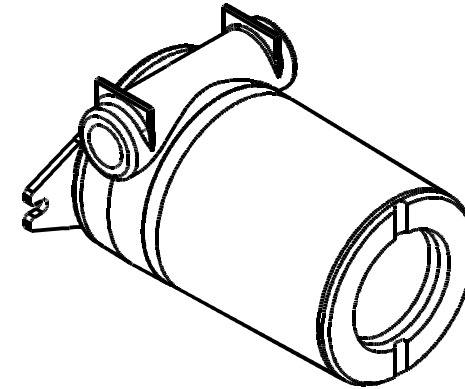
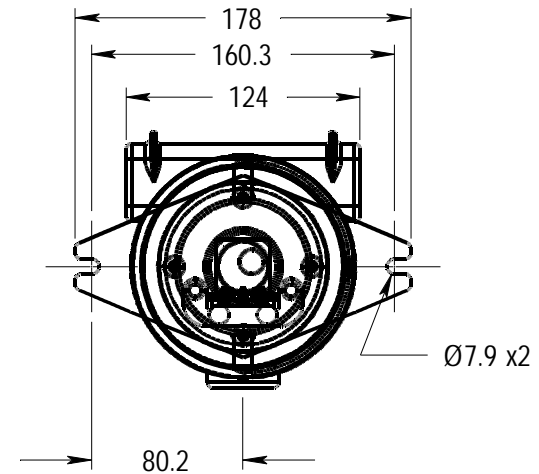

Material: Aluminum
Ratings: NEMA 3, 4X, 7 & 9

Compliances: NEC
Class I, Groups A, B & C
Class II, Groups E, F & G
Class III

Approvals:
UL Classified Standard 1203
CSA Certified Standard C22.2-30
FM Class No. 3615

					Name	Date	Title	
				Created By	ccm	2007/12/19	Universal Arm for 30mm high cameras	
				Checked By				
				Scale				
No	Change	Date	Init	Allison Park Group, Inc. (APG) 4091 Route 8, Suite 300 Allison Park, PA 15101 USA Phone +1 (412) 487-8211 Fax +1 (412) 486-3157 www.apgvision.com			Drawing Number	Issue
<small>This document is the property of APG and is considered company confidential. The information in this document is the property of APG and may not be used, reproduced or distributed in whole or in part without the prior written permission of APG.</small>							C2-AG	1.0