

1 2 3 4 5 6

A

B

C

D

A

B

C

D

REVISIONS				
ZONE	REV.	DESCRIPTION	DATE	APPROVED
	A	RELEASED FOR PRODUCTION	11/1/2021	DMM

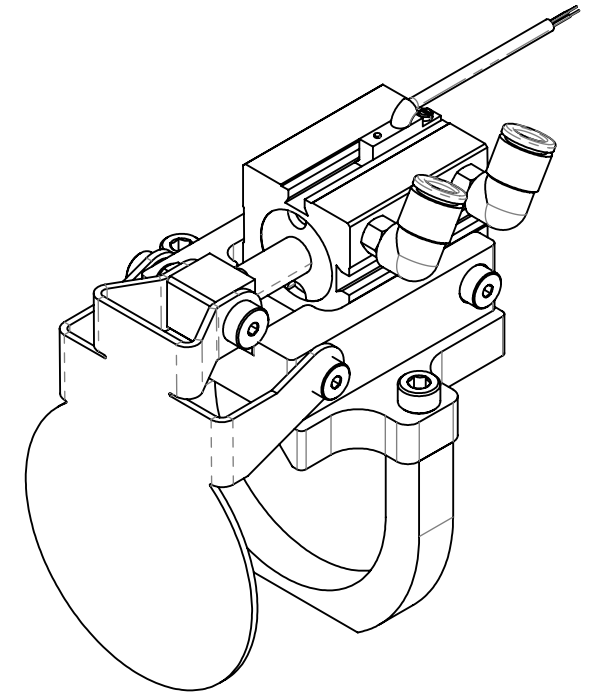
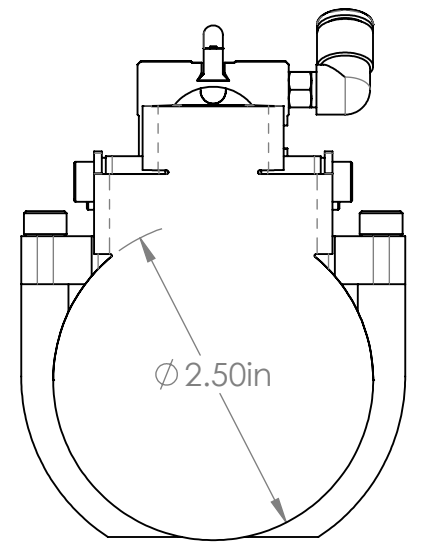
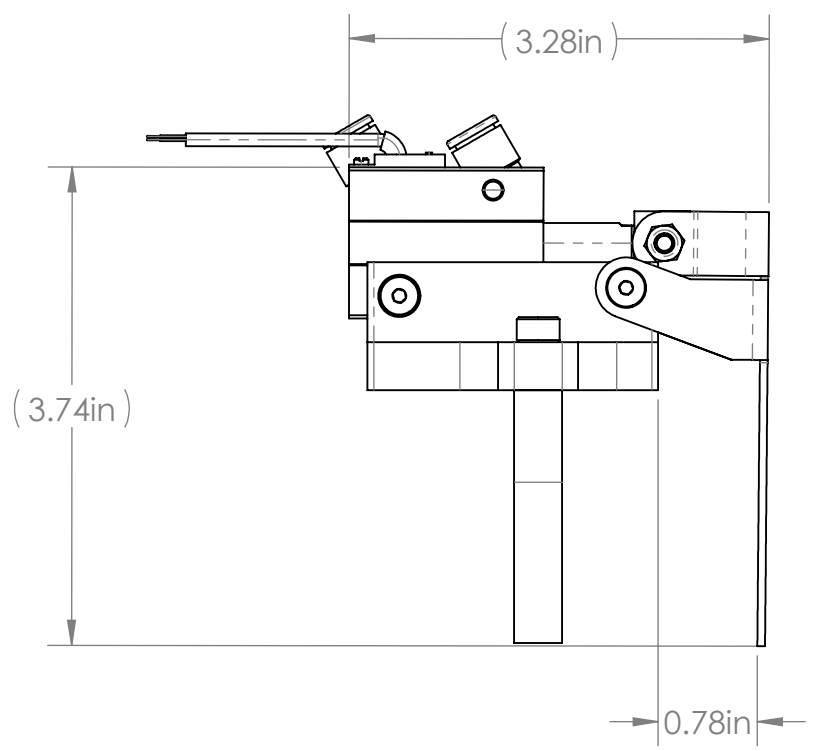
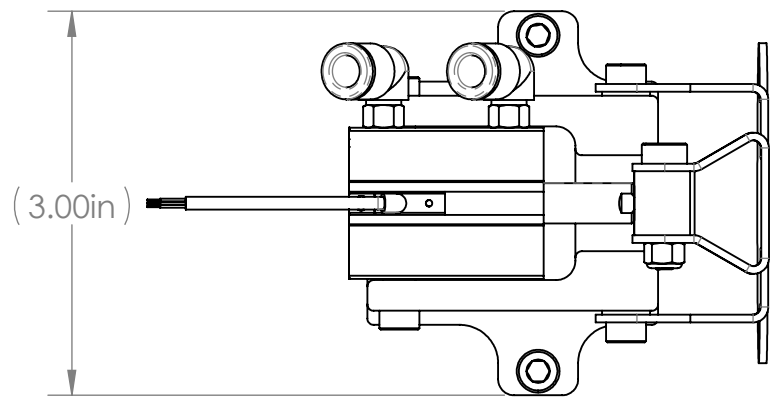

**SA SERIES PROPERTIES TABLE**

COMPONENT	MATERIAL	FINISH
SHUTTER	5052 ALUMINUM	CLEAR HARDCOAT ANODIZED
ADAPTER	6061 ALUMINUM	CLEAR HARDCOAT ANODIZED
PNEUMATIC CYLINDER	ALUMINUM	AS SUPPLIED
HARDWARE	18-8 SS	AS SUPPLIED

TOLERANCES UNLESS OTHERWISE SPECIFIED

MACHINING		SHEET METAL	
X.X	0.0250"	HOLE TO HOLE (SAME SURFACE)	
X.XX	0.0100"	X.X	0.030"
X.XXX	0.0050"	X.XX	0.010"
X.XXXX	0.0005"	X.XXX	0.005"
ANGULAR	0.5°	HOLE TO FOLDED EDGE	
DEBURR ALL		X.X	0.035"
		X.XX	0.025"
		X.XXX	0.015"
		FOLD TO FOLD	
		X.X	0.045"
		X.XX	0.035"
		X.XXX	0.020"
		ANGULAR 1.0°	

THIS PRINT IS THE PROPERTY OF APG VISION LLC. THE INFORMATION CONTAINED HEREIN IS CONFIDENTIAL. IT IS NOT TRANSFERABLE. IT IS FURNISHED WITH THE CLEAR UNDERSTANDING THAT IT IS NOT TO BE TRACED, REPRODUCED OR USED IN ANY PROCESS OF MANUFACTURING WITHOUT WRITTEN PERMISSION FROM THE OWNER AND IS RETURNABLE UPON DEMAND. ANY INFRINGEMENT UPON THE PATENT RIGHTS SHOWN HEREIN, WHETHER IN PART OR WHOLE, WILL BE PROSECUTED.

AS PART OF OUR POLICY OF CONTINUING DEVELOPMENT, APG VISION LLC RESERVES THE RIGHT TO ALTER SPECIFICATIONS WITHOUT PRIOR NOTICE.

APG Vision LLC  
4055 Alpha Drive  
Allison Park, PA 15101 USA  
Phone +1 (412) 487-8211  
apgvision.com

DESCRIPTION:  
**22C SHUTTER ASSEMBLY**

MATERIAL: SEE PROPERTIES TABLE

FINISH: SEE PROPERTIES TABLE

DRAWN BY: TWD	DATE: 11/12/2021	SCALE: 2:3	SHT-SIZE: B	APPROX. WEIGHT (LBS): 0.6203
CHECKED BY: DMM	DATE: 11/11/2021	PART NUMBER: <b>SA-AC</b>		REVISION: A

Sheet1 of 1

1 2 3 4 5 6