

1 2 3 4 5 6

A

A

B

B

C

C

D

D

| REVISIONS | | | | |
|-----------|------|-------------------------|----------|----------|
| ZONE | REV. | DESCRIPTION | DATE | APPROVED |
| | A | RELEASED FOR PRODUCTION | 5/6/2022 | DMM |

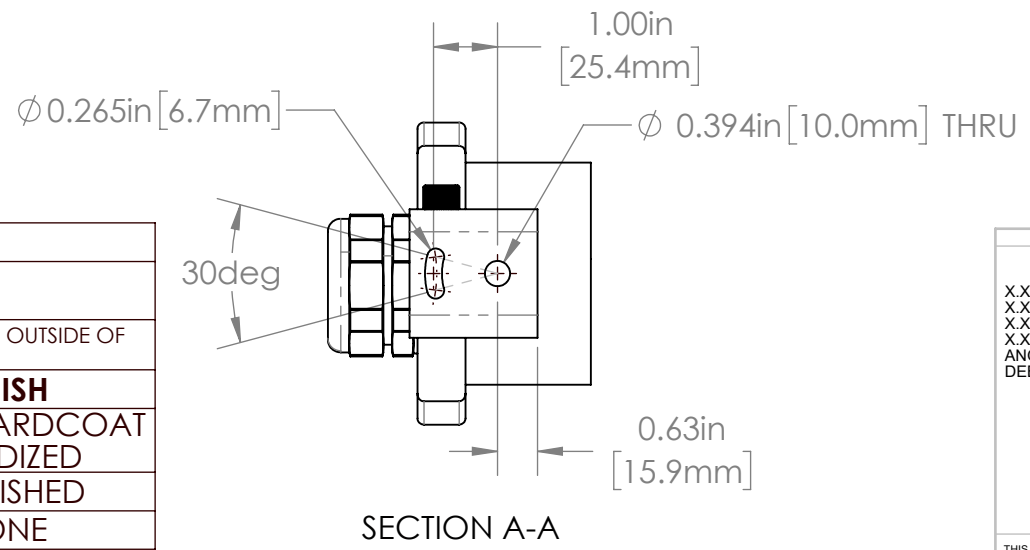
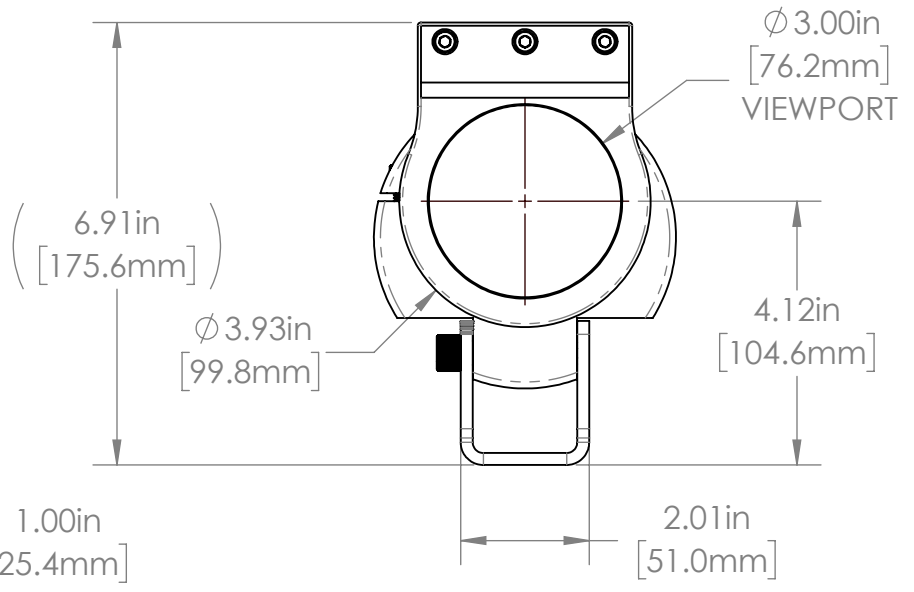
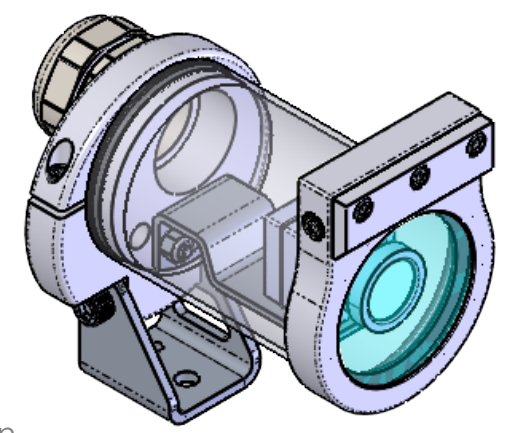
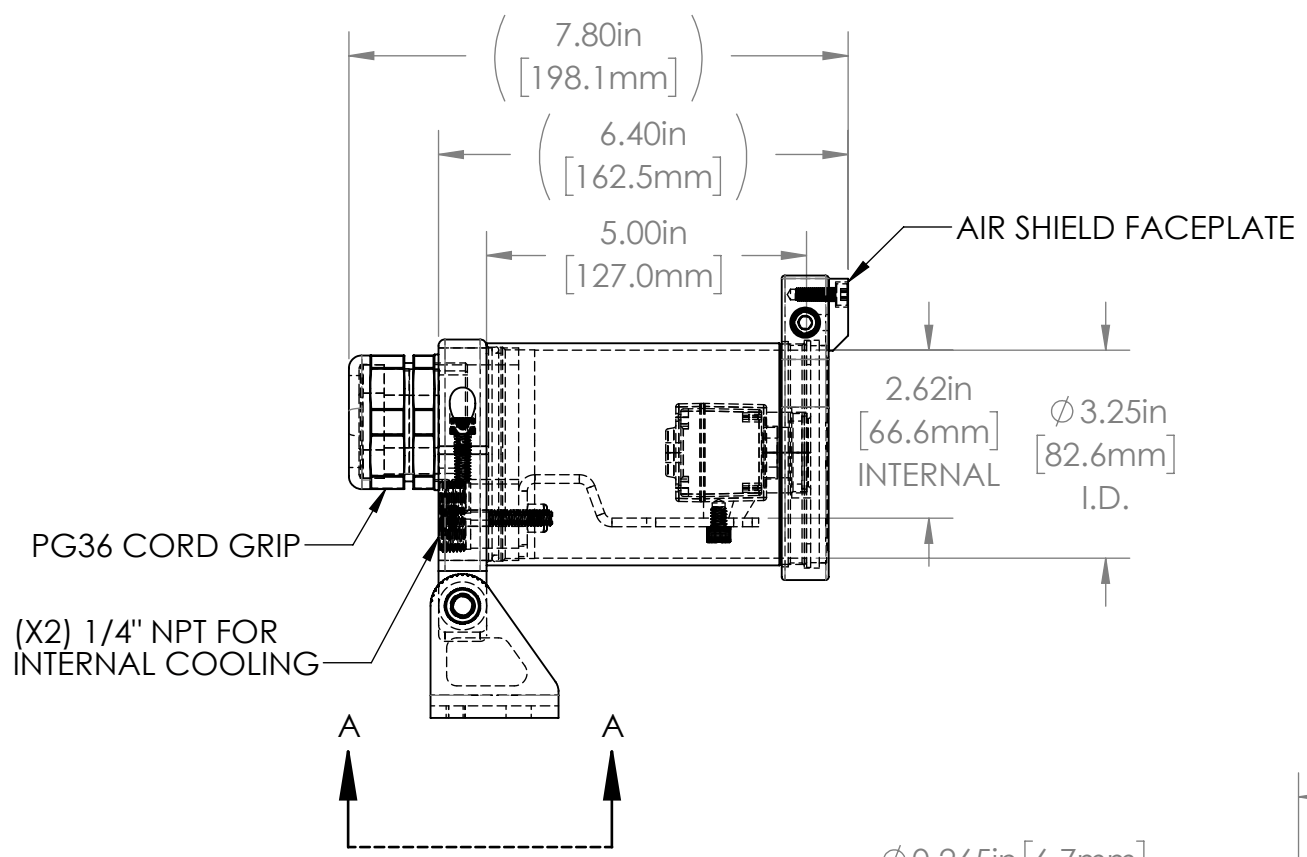
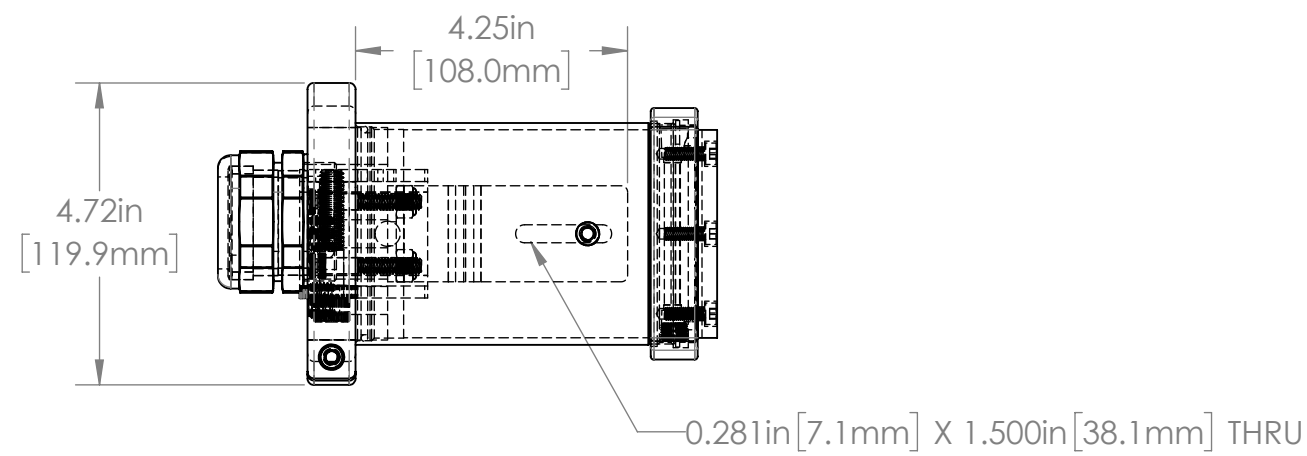

35C SERIES PROPERTIES TABLE

| | | |
|--------------------------------|--|----------------------------|
| ENVIRONMENT RATING | IP68* | |
| | (*RATING MAY CHANGE IF INSTALLER MILLS CABLE GLAND OUTSIDE OF TOLERANCE) | |
| COMPONENT | MATERIAL | FINISH |
| BODY/BASE/ BARREL/FACEPLATE | 6061 ALUMINUM | CLEAR HARDCOAT ANODIZED |
| FOOT | 304 SS | BURNISHED |
| VIEWPORT | BOROSILICATE GLASS | NONE |
| GASKET | VITON | NONE |
| ARM/ADAPTOR | 304 SS | NONE |
| HARDWARE | 18-8 SS | NONE |

| TOLERANCES UNLESS OTHERWISE SPECIFIED | | | |
|---------------------------------------|-------------|-----------------------------|--------|
| MACHINING | SHEET METAL | | |
| X.X | 0.0250" | HOLE TO HOLE (SAME SURFACE) | |
| X.XX | 0.0100" | X.X | 0.030" |
| X.XXX | 0.0050" | X.XX | 0.010" |
| X.XXXX | 0.0005" | X.XXX | 0.005" |
| ANGULAR | 0.5° | HOLE TO FOLDED EDGE | |
| DEBURR | ALL | X.X | 0.035" |
| | | X.XX | 0.025" |
| | | X.XXX | 0.015" |
| | | FOLD TO FOLD | |
| | | X.X | 0.045" |
| | | X.XX | 0.035" |
| | | X.XXX | 0.020" |
| | | ANGULAR | 1.0° |

APG Vision LLC
4055 Alpha Drive
Allison Park, PA 15101 USA
Phone +1 (412) 487-8211
apgvision.com

apgvision

DESCRIPTION:
35C SEALED 5IN BARREL, BOROSILICATE VIEWPORT,
CENTER SLOT ARM & AIR SHIELD FACEPLATE

MATERIAL: **SEE BOM**

FINISH: **SEE BOM**

| | | | | |
|--------------------|-------------------|-------------------------------|----------------|---------------------------------|
| DRAWN BY: DMM | DATE: 5/6/2022 | SCALE: 1:3 | SHT-SIZE: B | APPROX. WEIGHT (LBS): 3.6904 |
| CHECKED BY: DMM | DATE: 5/6/2022 | PART NUMBER: 35C-MH | | REVISION: A |

Sheet 1 of 1

1 2 3 4 5 6