

1 2 3 4 5 6

REVISIONS				
ZONE	REV.	DESCRIPTION	DATE	APPROVED
	A	RELEASED FOR PRODUCTION	10/13/2021	DMM

A

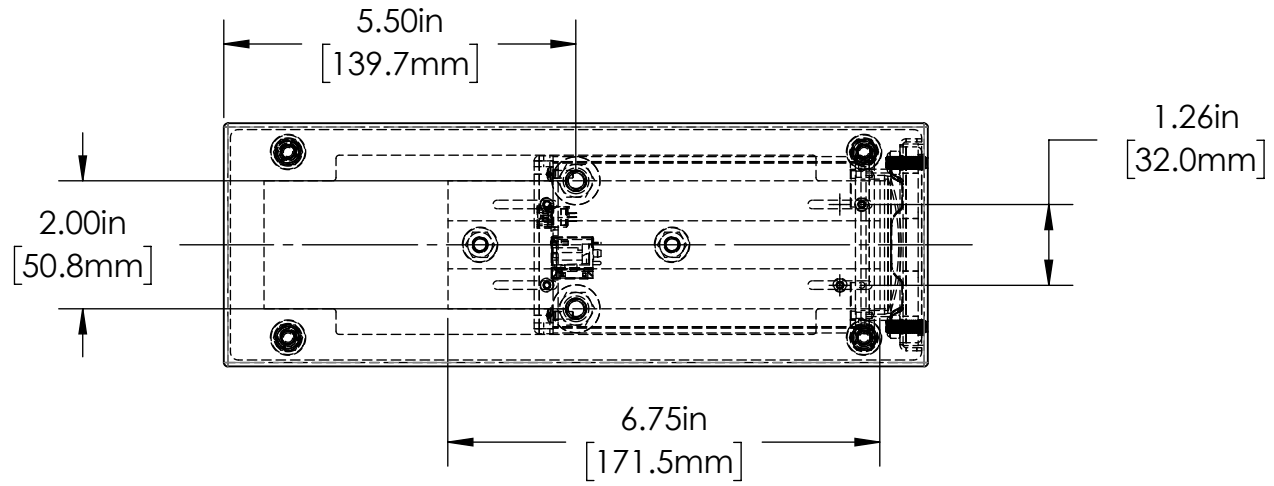

B

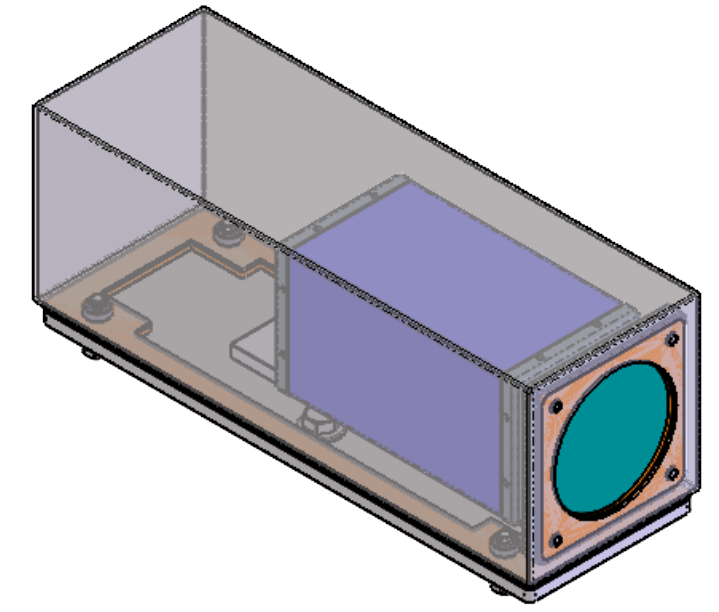

C

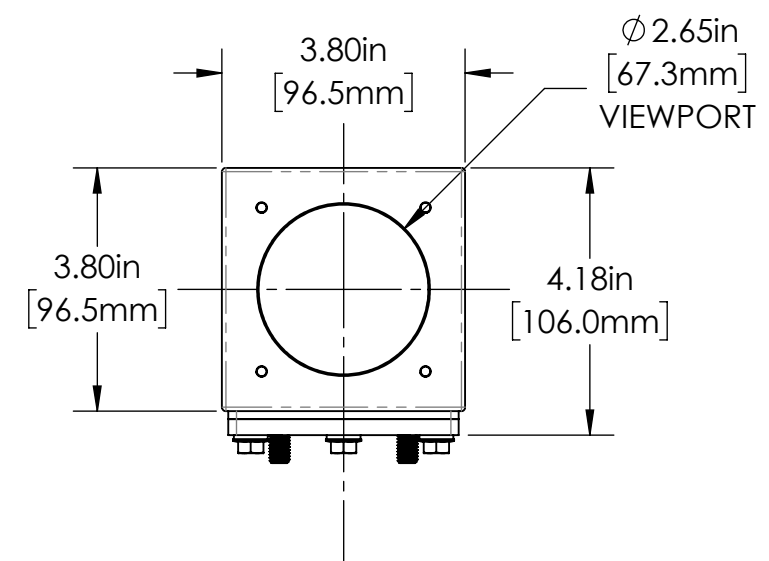
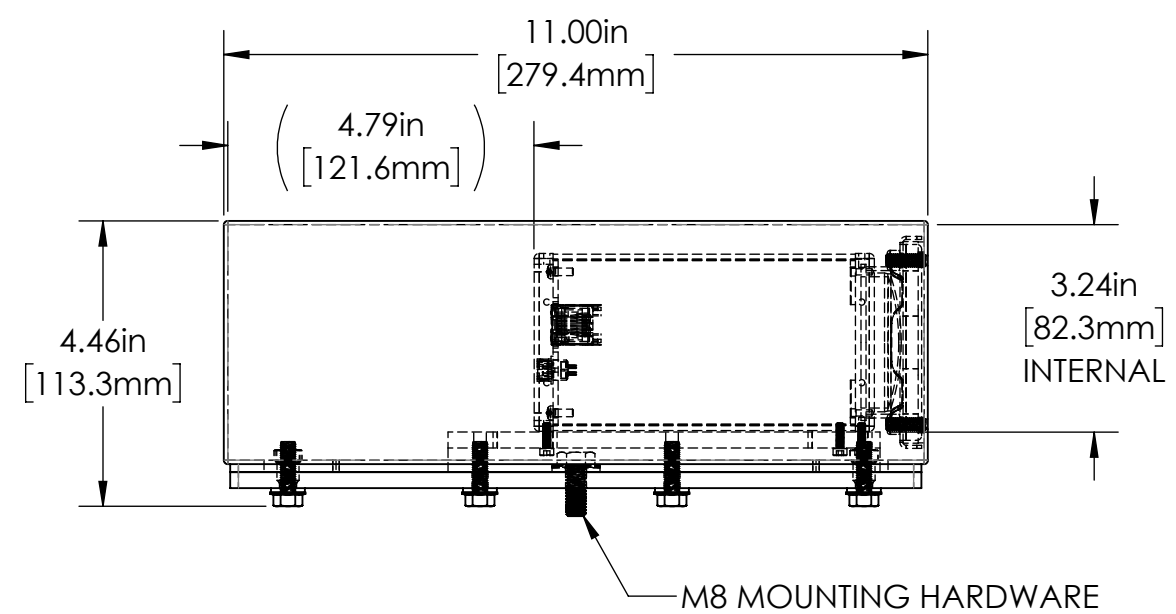

D

38S SERIES PROPERTIES TABLE		
ENVIRONMENT RATING	IP68*	
	(*RATING MAY CHANGE IF INSTALLER MILLS CABLE GLAND OUTSIDE OF TOLERANCE)	
COMPONENT	MATERIAL	FINISH
BODY/BASE	316 SS	BURNISHED
VIEWPORT	CLEAR ACRYLIC	ABR2
GASKET	SILICONE	NONE
ARM/ADAPTOR	6061 ALUMINUM	NONE
HARDWARE	316 SS - EXTERNAL, 18-8 SS - INTERNAL	NONE

TOLERANCES UNLESS OTHERWISE SPECIFIED	
MACHINING	SHEET METAL
X.X 0.0250"	HOLE TO HOLE (SAME SURFACE) X.X 0.030"
X.XX 0.0100"	X.XX 0.010"
X.XXX 0.0050"	X.XXX 0.005"
X.XXXX 0.0005"	X.XXX 0.015"
ANGULAR 0.5°	HOLE TO FOLDED EDGE X.X 0.035"
DEBURR ALL	X.XX 0.025"
	X.XXX 0.015"
	FOLD TO FOLD X.X 0.045"
	X.XX 0.035"
	X.XXX 0.020"
	ANGULAR 1.0°

APG Vision LLC
4055 Alpha Drive
Allison Park, PA 15101 USA
Phone +1 (412) 487-8211
apgvision.com

apgvision

DESCRIPTION:
**38S 11IN BODY SEALED ENCLOSURE
32mm O.C. ARM, NO CORD GRIP**

MATERIAL: SEE BOM

FINISH: SEE BOM

DRAWN BY: DMM	DATE: 10/13/2021	SCALE: 1:3	SHT-SIZE: B	APPROX. WEIGHT (LBS) 6.9164
CHECKED BY: DMM	DATE: 10/13/2021	PART NUMBER: 38S-GB		REVISION A

Sheet 1 of 1

1 2 3 4 5 6