

4

3

2

1

REVISIONS

ZONE	REV.	DESCRIPTION	DATE	APPROVED
	A		7/30/2019	

B

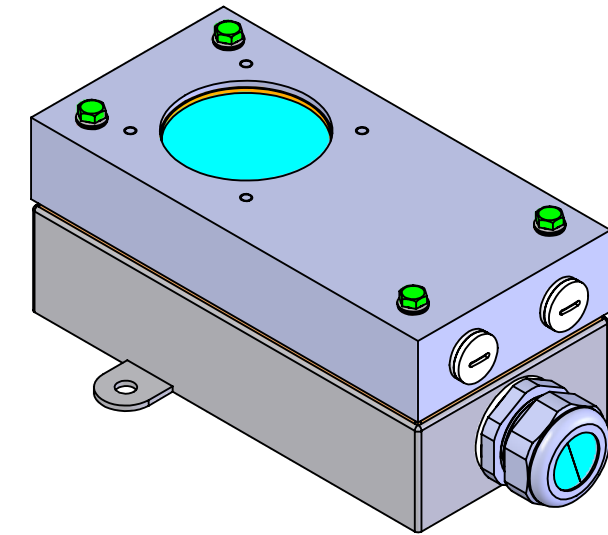
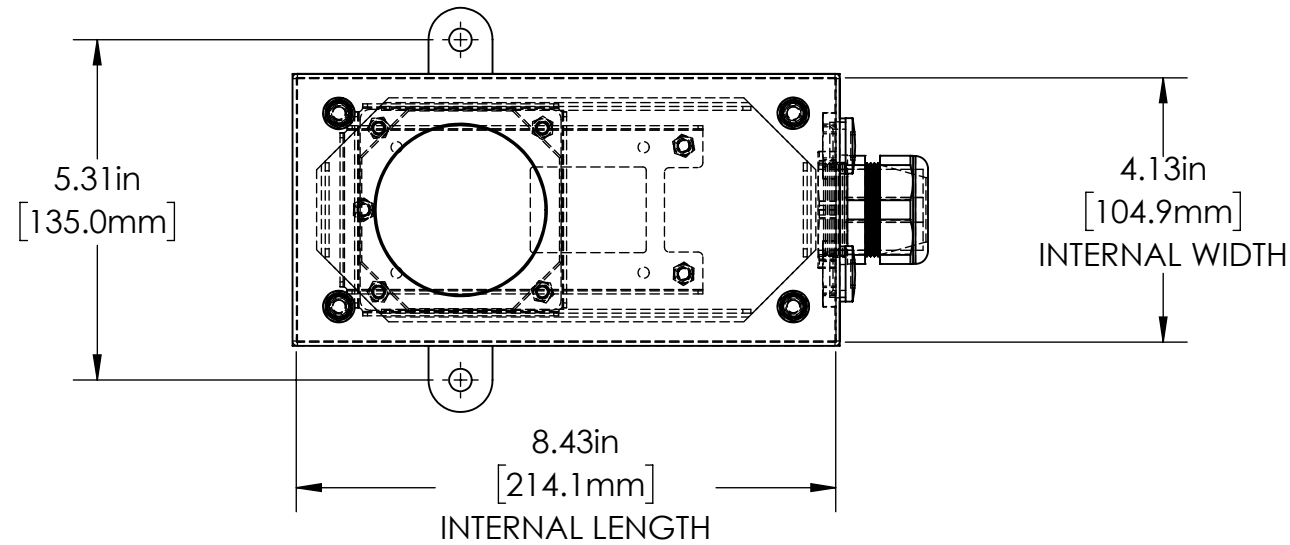

B

A

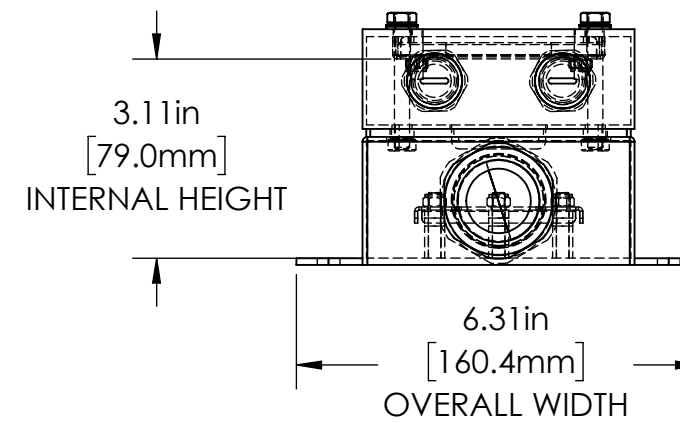
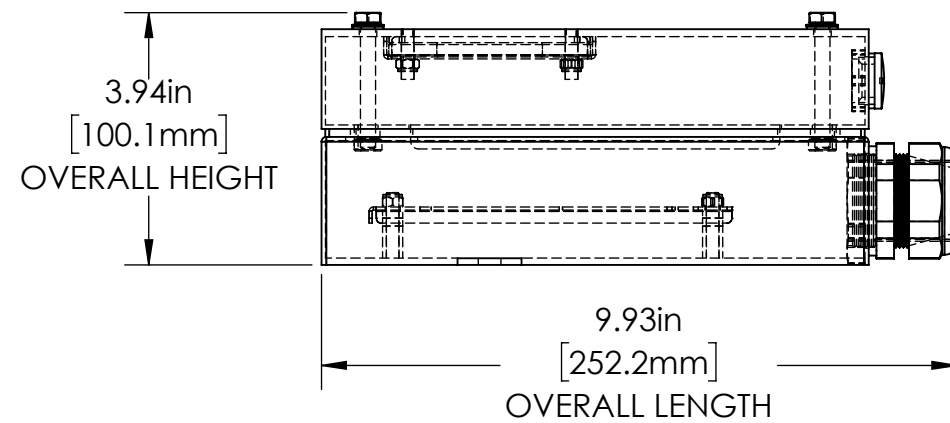

A

TOLERANCES UNLESS OTHERWISE SPECIFIED

MACHINING		SHEET METAL	
X.X	0.0250"	HOLE TO HOLE (SAME SURFACE)	
X.XX	0.0100"	X.X	0.030"
X.XXX	0.0050"	X.XX	0.010"
X.XXXX	0.0005"	X.XXX	0.005"
ANGULAR	0.5°	HOLE TO FOLDED EDGE	
DEBURR ALL		X.X	0.035"
		X.XX	0.025"
		X.XXX	0.015"
		FOLD TO FOLD	
		X.X	0.045"
		X.XX	0.035"
		X.XXX	0.020"
		ANGULAR 1.0°	

ALL WEIGHTS ARE IN POUNDS

THIS PRINT IS THE PROPERTY OF ALLISON PARK GROUP. THE INFORMATION CONTAINED HEREIN IS CONFIDENTIAL. IT IS NOT TRANSFERABLE. IT IS FURNISHED WITH THE CLEAR UNDERSTANDING THAT IT IS NOT TO BE TRACED, REPRODUCED OR USED IN ANY PROCESS OF MANUFACTURING WITHOUT WRITTEN PERMISSION FROM THE OWNER AND IS RETURNABLE UPON DEMAND. ANY INFRINGEMENT UPON THE PATENT RIGHTS SHOWN HEREIN, WHETHER IN PART OR WHOLE, WILL BE PROSECUTED.

AS PART OF OUR POLICY OF CONTINUING DEVELOPMENT, ALLISON PARK GROUP RESERVES THE RIGHT TO ALTER SPECIFICATIONS WITHOUT PRIOR NOTICE.



Allison Park Group, Inc (APG)
4055 Alpha Drive
Allison Park, PA 15101 USA
Phone +1 (412) 487-8211
apgvision.com

DESCRIPTION:
L7-AB ENCLOSURE FOR COGNEX 5000 CAMERA

MATERIAL:
SEE BOM

FINISH: **SEE BOM**

DRAWN BY:	DATE:	SCALE:	SHT-SIZE:	APPROX. WEIGHT
KENNEDY	8/12/2019	1:3	B	0.9050
CHECKED BY:	DATE:	PART NUMBER:	REVISION	
		L7-AB	A	

Sheet 1 of 1

4

3

2

1