

LENS CLEARANCE TO "C" MOUNT

1.439in
[36.56mm]

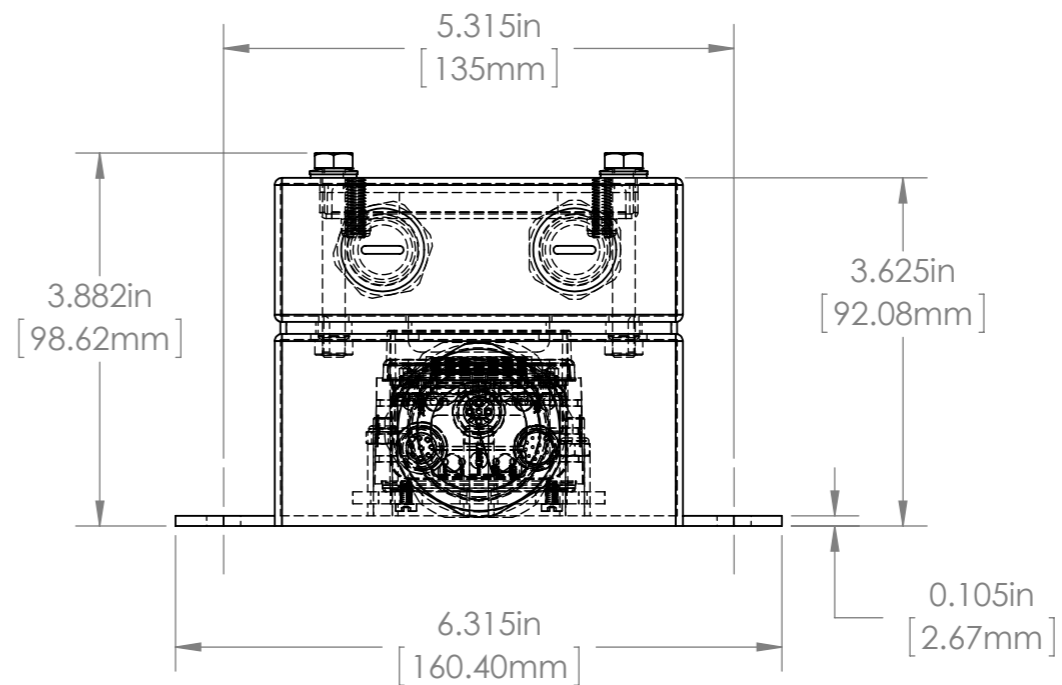
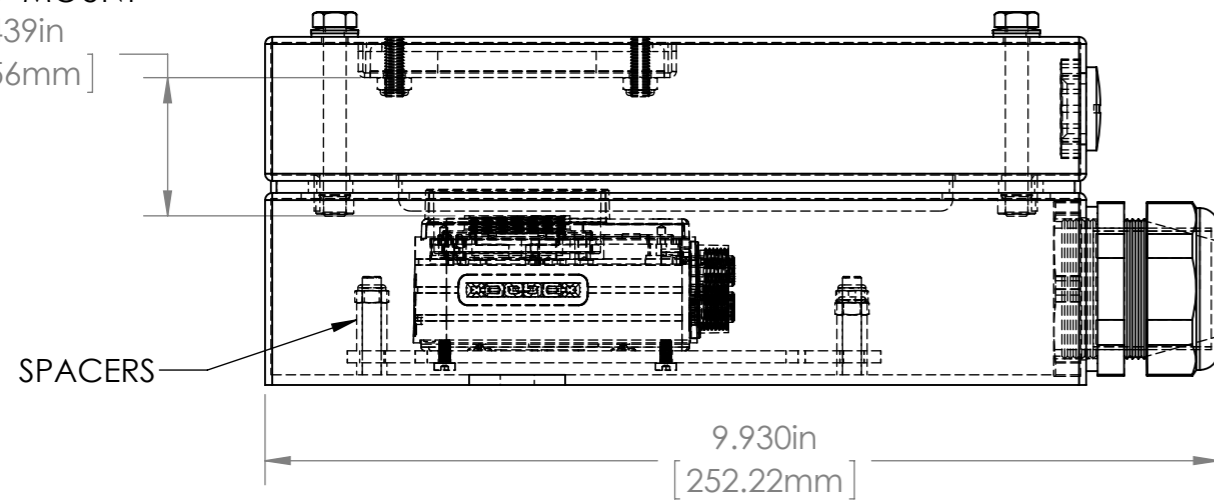

				UNLESS OTHERWISE SPECIFIED: DIMENSIONS ARE IN INCHES SURFACE FINISH: TOLERANCES: .000= +/- 0.005" .00= +/- 0.010"		FINISH: DEBUR AND BREAK SHARP EDGES		Allison Park Group, Inc. (APG) 4055 Alpha Drive Allison Park, PA 15101 USA		DO NOT SCALE DRAWING		REVISION	
				LINEAR:				Phone +1 (412) 487-8211 Fax +1 (412) 486-3157		This document is the property of APG and is considered company confidential. The information in this document is the property of APG and may not be used, reproduced, or distributed in whole or in part without the prior written permission of APG		TITLE:	
				DRAWN		NAME		www.apgvision.com		TITLE:		L7-AX (COGNEX IS7000) ASSY	
				CHK'D		SIGNATURE		MATERIAL:		DWG NO.		A3	
				APPVD		DATE		WEIGHT:		SCALE:1:2		SHEET 1 OF 1	
				MFG									
				Q.A									
				NOTES:									
NO.		CHANGE		DATE		INIT.							