

2.246in MAX
 [57.04mm]
 ADJUSTABLE WITH SPACERS

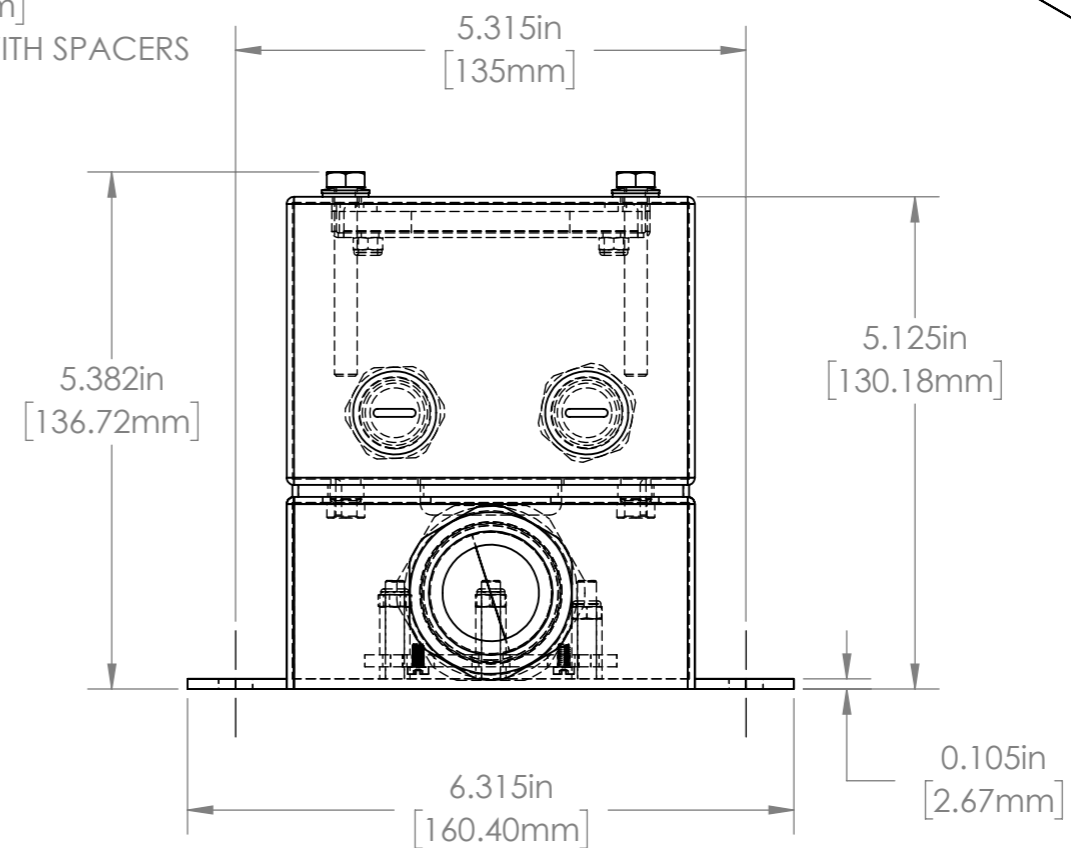
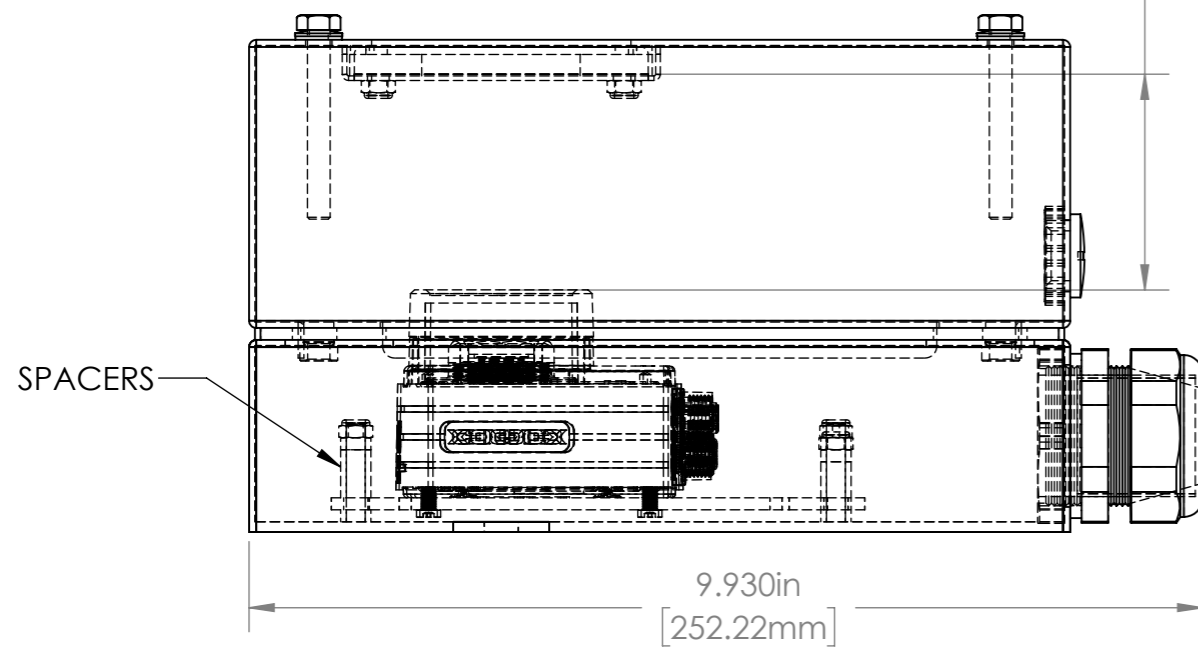

				UNLESS OTHERWISE SPECIFIED: DIMENSIONS ARE IN INCHES SURFACE FINISH: TOLERANCES: .000= +/- 0.005" .00= +/- 0.010" LINEAR:		FINISH: DEBUR AND BREAK SHARP EDGES		Allison Park Group, Inc. (APG) 4055 Alpha Drive Allison Park, PA 15101 USA Phone +1 (412) 487-8211 Fax +1 (412) 486-3157 www.apgvision.com		DO NOT SCALE DRAWING REVISION	
				DRAWN SCHUBERT CHK'D APPVD MFG Q.A NOTES:		SIGNATURE DATE 8/14/2017		TITLE: L7-BD (COGNEX IS7000 EXTENDED LID) ASSY		This document is the property of APG and is considered company confidential. The information in this document is the property of APG and may not be used, reproduced, or distributed in whole or in part without the prior written permission of APG.	
				MATERIAL:		DWG NO. L7-BD ASSY		SCALE: 1:2		SHEET 1 OF 1	
NO. CHANGE DATE INIT.				WEIGHT:		A3					