

LENS CLEARANCE TO "C" MOUNT

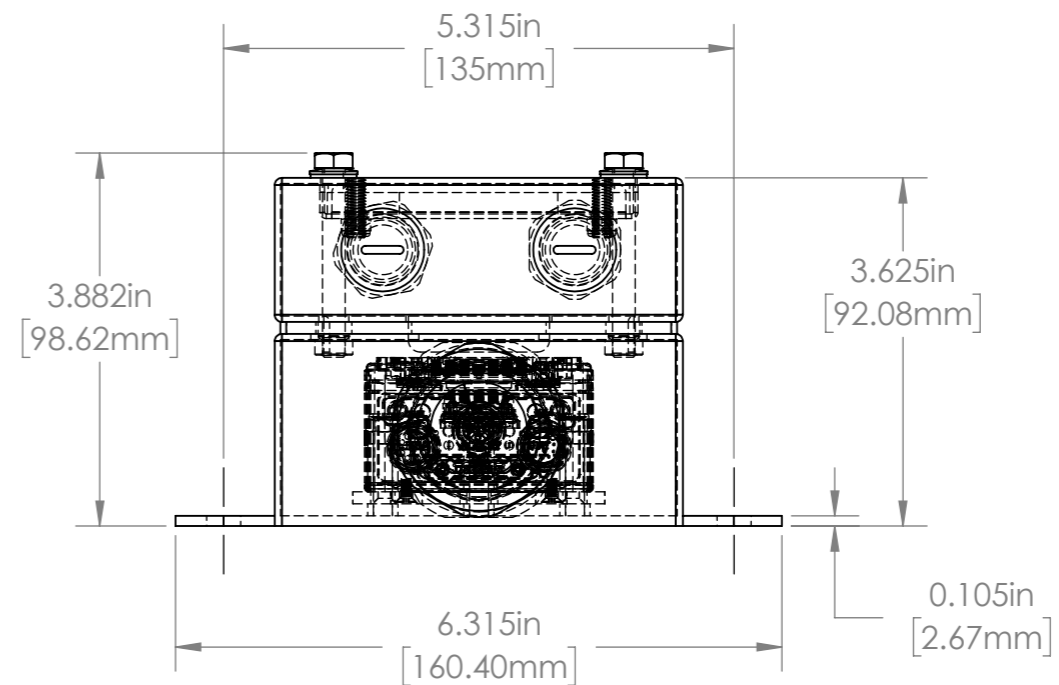
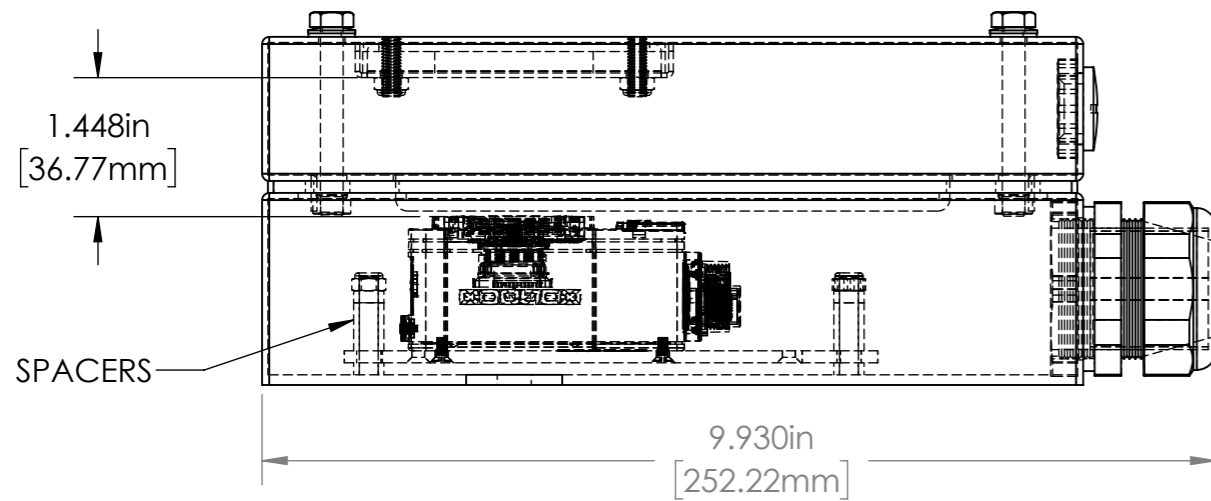

				UNLESS OTHERWISE SPECIFIED: DIMENSIONS ARE IN INCHES SURFACE FINISH: TOLERANCES: .000= +/- 0.005" .00= +/- 0.010"		FINISH: DEBUR AND BREAK SHARP EDGES		Allison Park Group, Inc. (APG) 4055 Alpha Drive Allison Park, PA 15101 USA		DO NOT SCALE DRAWING		REVISION	
				LINEAR:				Phone +1 (412) 487-8211 Fax +1 (412) 486-3157 www.apgvision.com		This document is the property of APG and is considered company confidential. The information in this document is the property of APG and may not be used, reproduced, or distributed in whole or in part without the prior written permission of APG			
				DRAWN		SIGNATURE		MATERIAL:		TITLE: L7-BR (COGNEX IS7000G2) ASSY			
				SCHUBERT				WEIGHT: .		DWG NO. L7-BR ASSY			
				CHK'D				SCALE: 1:2		SHEET 1 OF 1			
				APPV'D						A3			
				MFG									
				Q.A									
				NOTES:									
				NO.		CHANGE		DATE		INIT.			