

4

3

2

1

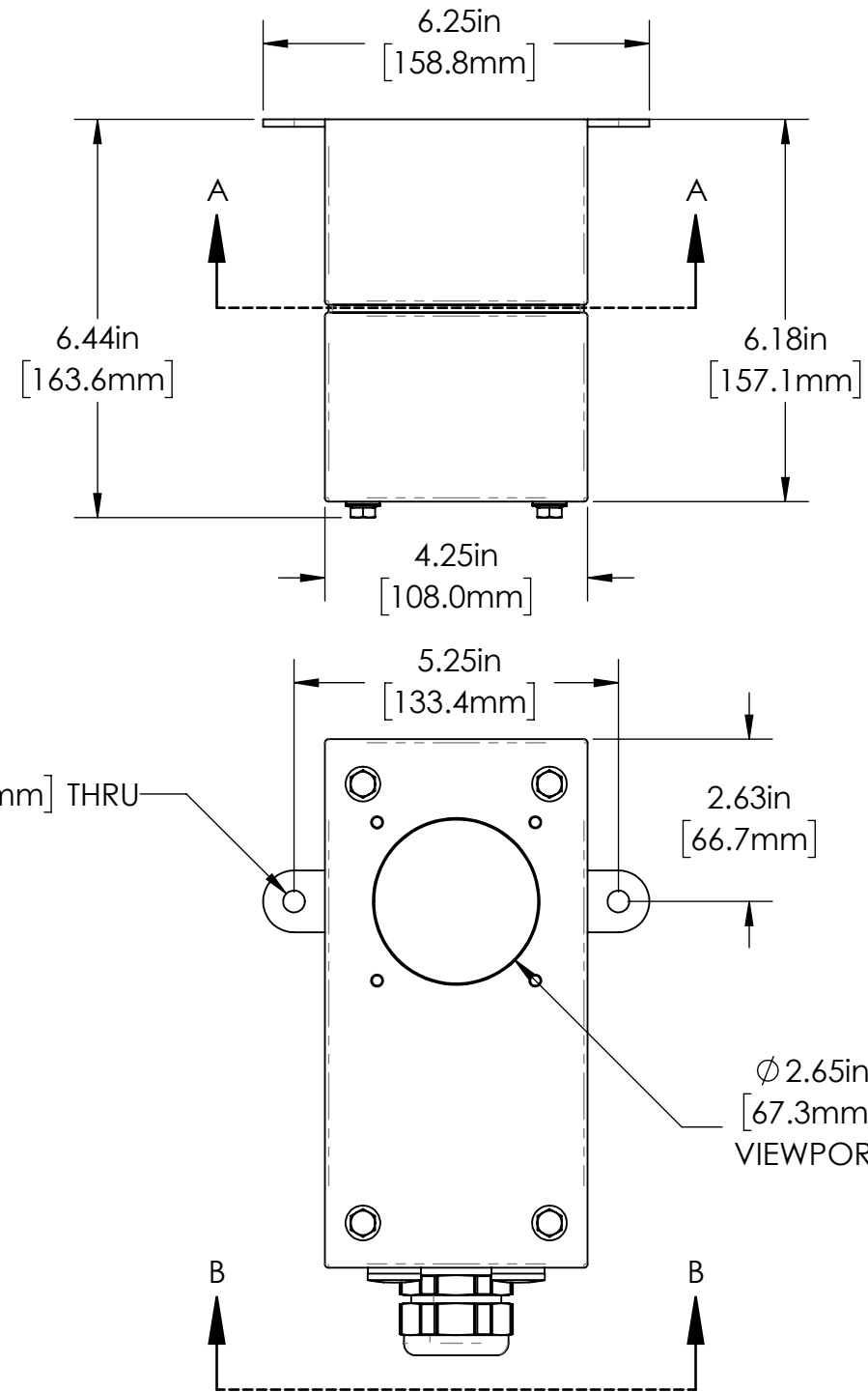

DISTANCE TO WINDOW
ADJUSTABLE WITH
PROVIDED SPACERS

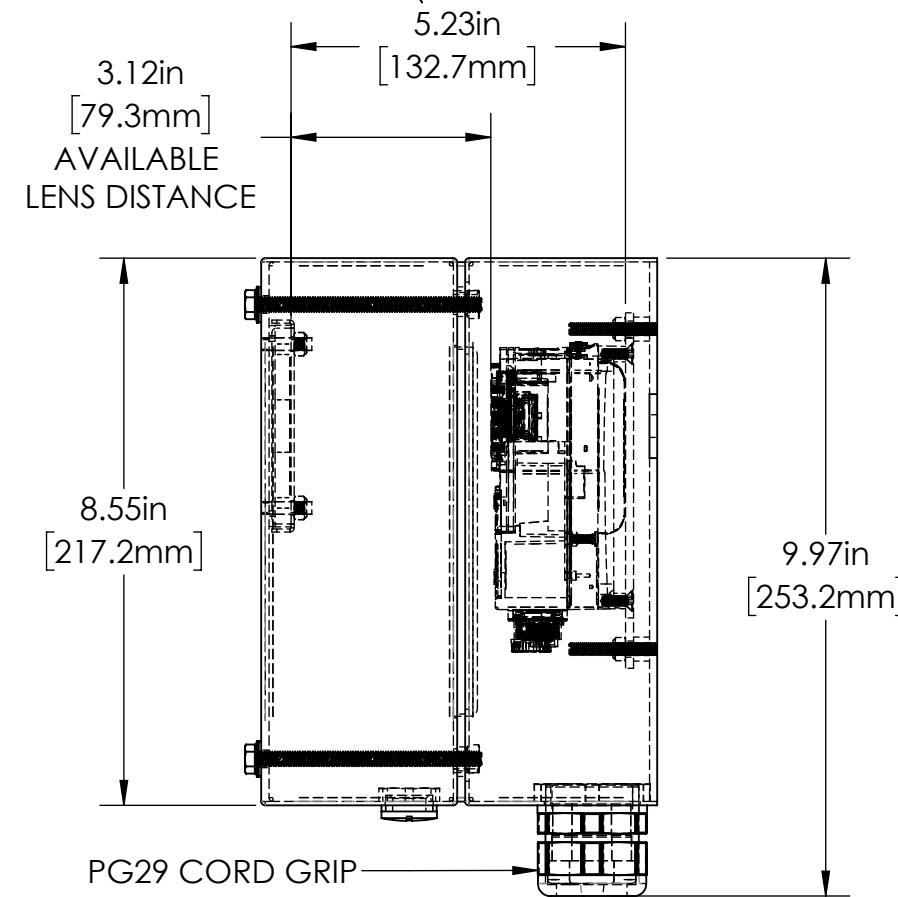

REVISIONS				
ZONE	REV.	DESCRIPTION	DATE	APPROVED
	A	RELEASED FOR PRODUCTION	10/23/2020	DMM

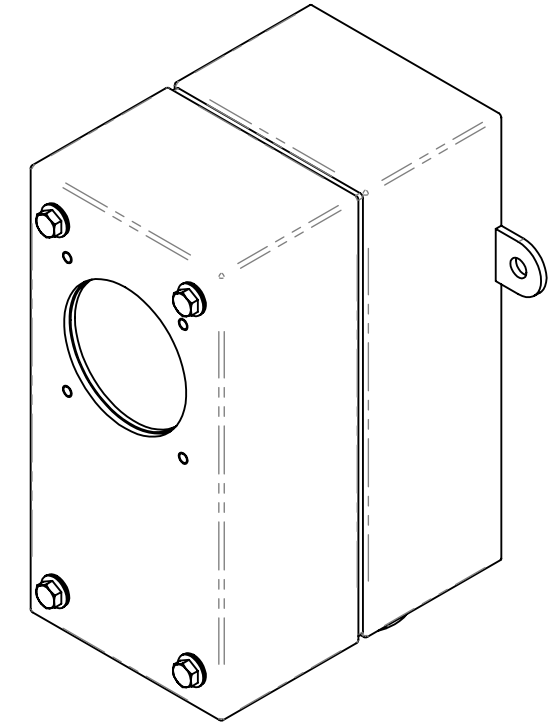

L7 PROPERTIES TABLE

ENVIRONMENT RATING	IP68*	
	(*RATING MAY CHANGE IF INSTALLER MILLS CABLE GLAND OUTSIDE OF TOLERANCE)	
COMPONENT	MATERIAL	FINISH
BODY	316 SS	BURNISHED
VIEWPORT	ACRYLIC	ABR2
GASKET	40D SILICONE	NONE
ARM/ADAPTOR	6061 ALUM	AS SUPPLIED
HARDWARE	316 SS - EXTERNAL, 18-8 SS - INTERNAL	AS SUPPLIED

TOLERANCES UNLESS OTHERWISE SPECIFIED

MACHINING		SHEET METAL	
X.X	0.0250"	HOLE TO HOLE (SAME SURFACE)	
X.XX	0.0100"	X.X	0.030"
X.XXX	0.0050"	X.XX	0.010"
X.XXXX	0.0005"	X.XXX	0.005"
ANGULAR	0.5°	X.XXX	0.015"
DEBURR ALL		HOLE TO FOLDED EDGE	
		X.X	0.035"
		X.XX	0.025"
		X.XXX	0.015"
		FOLD TO FOLD	
		X.X	0.045"
		X.XX	0.035"
		X.XXX	0.020"
		ANGULAR 1.0°	



THIS PRINT IS THE PROPERTY OF ALLISON PARK GROUP. THE INFORMATION CONTAINED HEREIN IS CONFIDENTIAL. IT IS NOT TRANSFERABLE. IT IS FURNISHED WITH THE CLEAR UNDERSTANDING THAT IT IS NOT TO BE TRACED, REPRODUCED OR USED IN ANY PROCESS OF MANUFACTURING WITHOUT WRITTEN PERMISSION FROM THE OWNER AND IS RETURNABLE UPON DEMAND. ANY INFRINGEMENT UPON THE PATENT RIGHTS SHOWN HEREIN, WHETHER IN PART OR WHOLE, WILL BE PROSECUTED.

AS PART OF OUR POLICY OF CONTINUING DEVELOPMENT, ALLISON PARK GROUP RESERVES THE RIGHT TO ALTER SPECIFICATIONS WITHOUT PRIOR NOTICE.

apg

Allison Park Group, Inc (APG)
4055 Alpha Drive
Allison Park, PA 15101 USA
Phone +1 (412) 487-8211
apgvision.com

DESCRIPTION:
**L7 ENCLOSURE FOR COGNEX D900
(EXTENDED UPPER & LOWER)**

MATERIAL: **SEE BOM**

FINISH: **SEE BOM**

DRAWN BY: DMM	DATE: 10/23/2020	SCALE: 1:3	SHT-SIZE: B	APPROX. WEIGHT
CHECKED BY: DMM	DATE: 10/23/2020	PART NUMBER: L7-EE	REVISION: A	

Sheet1 of 2

4

3

2

1

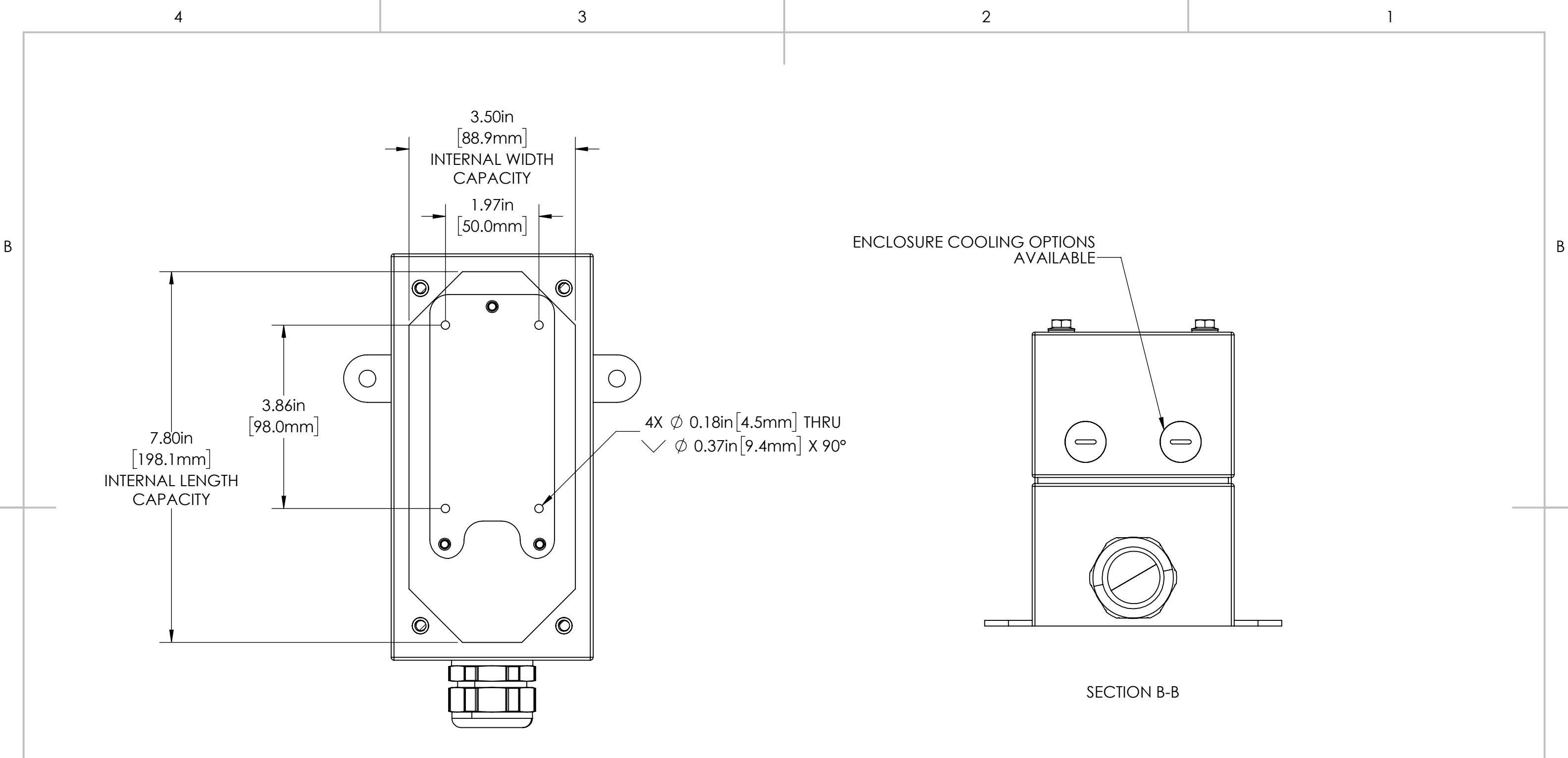

TOLERANCES UNLESS OTHERWISE SPECIFIED

MACHINING		SHEET METAL	
X.X	0.0250"	HOLE TO HOLE (SAME SURFACE)	
X.XX	0.0100"	X.X	0.030"
X.XXX	0.0050"	X.XX	0.010"
X.XXXX	0.0005"	X.XXX	0.005"
ANGULAR	0.5°	HOLE TO FOLDED EDGE	
DEBURR ALL		X.X	0.035"
		X.XX	0.025"
		X.XXX	0.015"
		FOLD TO FOLD	
		X.X	0.045"
		X.XX	0.035"
		X.XXX	0.020"
		ANGULAR 1.0°	

ALL WEIGHTS ARE IN POUNDS

THIS PRINT IS THE PROPERTY OF ALLISON PARK GROUP. THE INFORMATION CONTAINED HEREIN IS CONFIDENTIAL. IT IS NOT TRANSFERABLE. IT IS FURNISHED WITH THE CLEAR UNDERSTANDING THAT IT IS NOT TO BE TRACED, REPRODUCED OR USED IN ANY PROCESS OF MANUFACTURING WITHOUT WRITTEN PERMISSION FROM THE OWNER AND IS RETURNABLE UPON DEMAND. ANY INFRINGEMENT UPON THE PATENT RIGHTS SHOWN HEREIN, WHETHER IN PART OR WHOLE, WILL BE PROSECUTED.

AS PART OF OUR POLICY OF CONTINUING DEVELOPMENT, ALLISON PARK GROUP RESERVES THE RIGHT TO ALTER SPECIFICATIONS WITHOUT PRIOR NOTICE.

apg Allison Park Group, Inc (APG)
4055 Alpha Drive
Allison Park, PA 15101 USA
Phone +1 (412) 487-8211
apgvision.com

DESCRIPTION:
**L7 ENCLOSURE FOR COGNEX D900
(EXTENDED UPPER & LOWER)**

MATERIAL: **SEE BOM**

FINISH: **SEE BOM**

DRAWN BY: DMM	DATE: 10/23/2020	SCALE: 1:2	SHT-SIZE: B	APPROX. WEIGHT
CHECKED BY: DMM	DATE: 10/23/2020	PART NUMBER: L7-EE		REVISION: A

Sheet2 of 2