

1 2 3 4 5 6

A

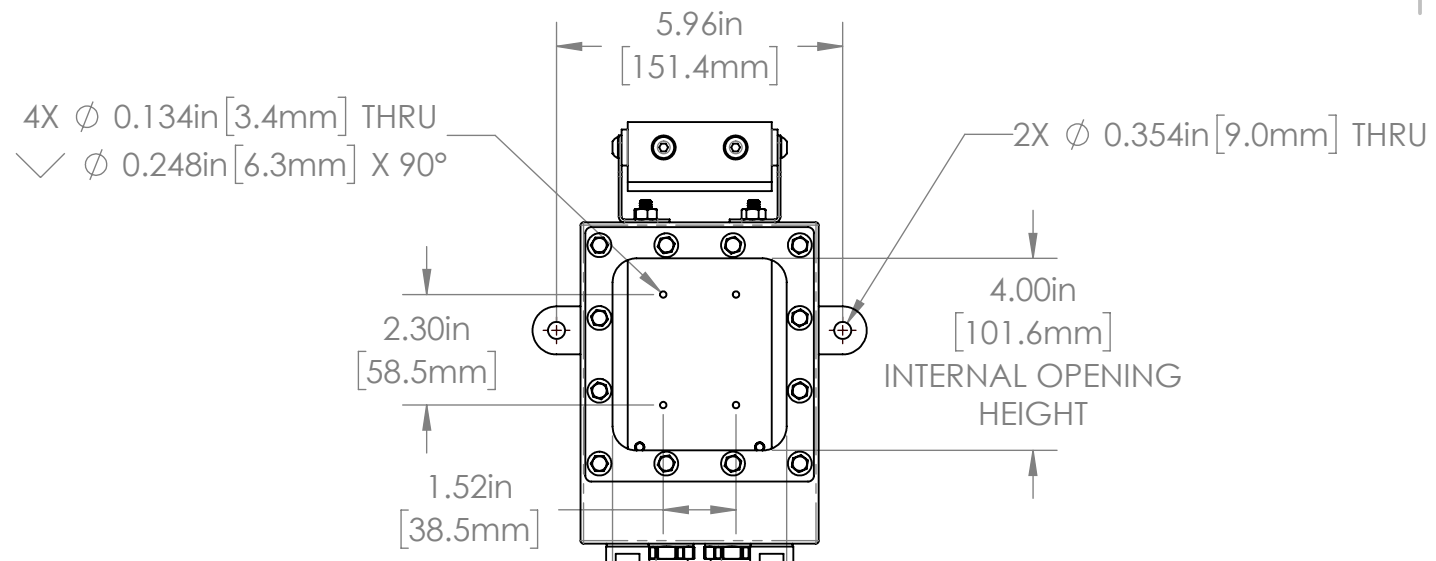

REVISIONS				
ZONE	REV.	DESCRIPTION	DATE	APPROVED
	A	CHANGE CORD GRIP LOCATIONS AND QTY RELEASED FOR PRODUCTION	9/8/2021	DMM
	B	REMOVED AIR KNIFE	10/26/2021	DMM
B5	C	ADDED AIR KNIFE	3/31/2022	DMM

B

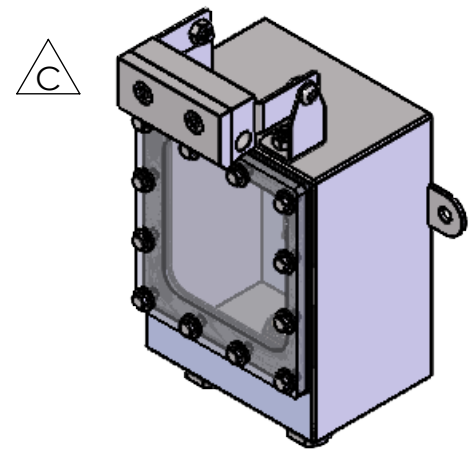
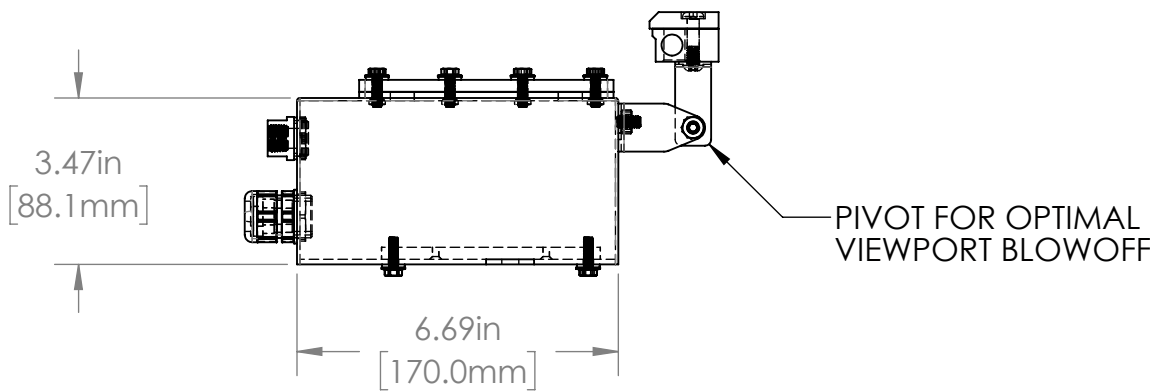
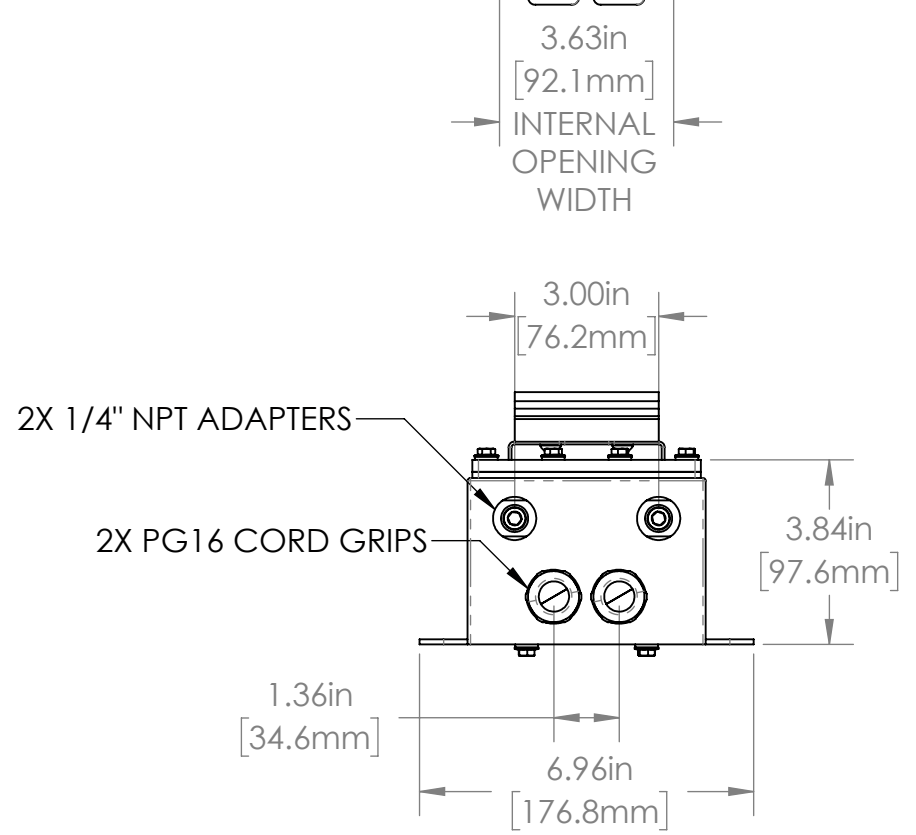

C

LD SERIES PROPERTIES TABLE		
ENVIRONMENT RATING	IP68*	FDA WASHDOWN
	(*RATING MAY CHANGE IF INSTALLER MILLS CABLE GLAND OUTSIDE OF TOLERANCE)	
COMPONENT	MATERIAL	FINISH
BODY	316 SS	BURNISHED
VIEWPORT	POLYCARBONATE	NONE
GASKET	VITON	NONE
ARM/ADAPTOR	6061 ALUM	NONE
HARDWARE	316 SS - EXTERNAL, 18-8 SS - INTERNAL	NONE

TOLERANCES UNLESS OTHERWISE SPECIFIED			
MACHINING		SHEET METAL	
X.X	0.0250"	HOLE TO HOLE (SAME SURFACE)	
X.XX	0.0100"	X.X	0.030"
X.XXX	0.0050"	X.XX	0.010"
X.XXXX	0.0005"	X.XXX	0.005"
ANGULAR	0.5°	X.XXX	0.015"
DEBURR	ALL	HOLE TO FOLDED EDGE	
		X.X	0.035"
		X.XX	0.025"
		X.XXX	0.015"
		FOLD TO FOLD	
		X.X	0.045"
		X.XX	0.035"
		X.XXX	0.020"
		ANGULAR 1.0°	

APG Vision LLC
4055 Alpha Drive
Allison Park, PA 15101 USA
Phone +1 (412) 487-8211
apgvision.com

apgvision

DESCRIPTION:
LD FDA ENCLOSURE WITH PIVOTING AIR KNIFE BRACKETS AND AIR COOLING ADAPTERS

MATERIAL: **SEE PROPERTIES TABLE**

FINISH: **SEE PROPERTIES TABLE**

DRAWN BY:	DATE:	SCALE:	SHT-SIZE:	APPROX. WEIGHT (LBS)
TWD	9/7/2021	1:4	B	5.1617
CHECKED BY:	DATE:	PART NUMBER:	REVISION	
DMM	9/8/2021	LD-EO	C	

Sheet 1 of 1

D

1 2 3 4 5 6