

NOTE: OPTIONAL HEATER COMPONENTS NOT SHOWN

REVISIONS				
ZONE	REV.	DESCRIPTION	DATE	APPROVED
	A	RELEASED FOR PRODUCTION	12/7/2021	DMM

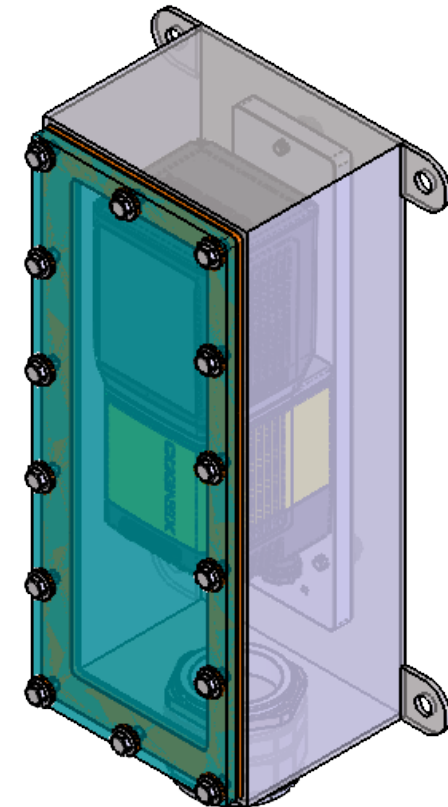
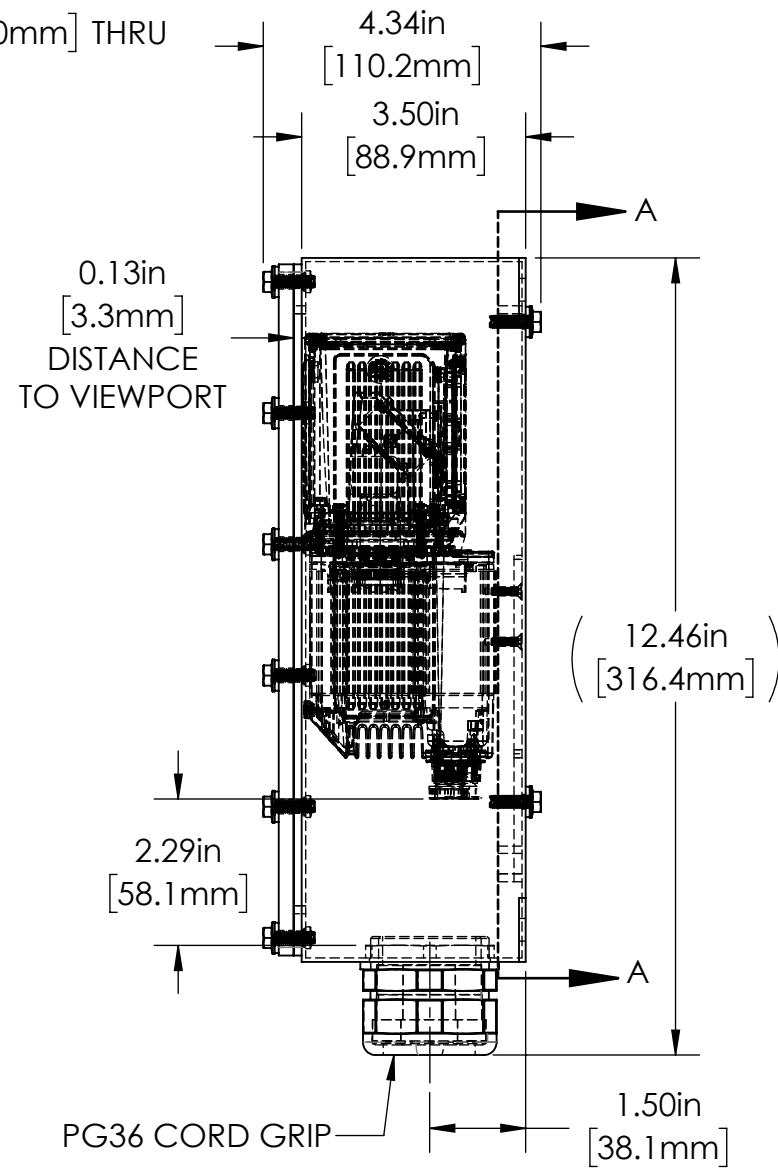
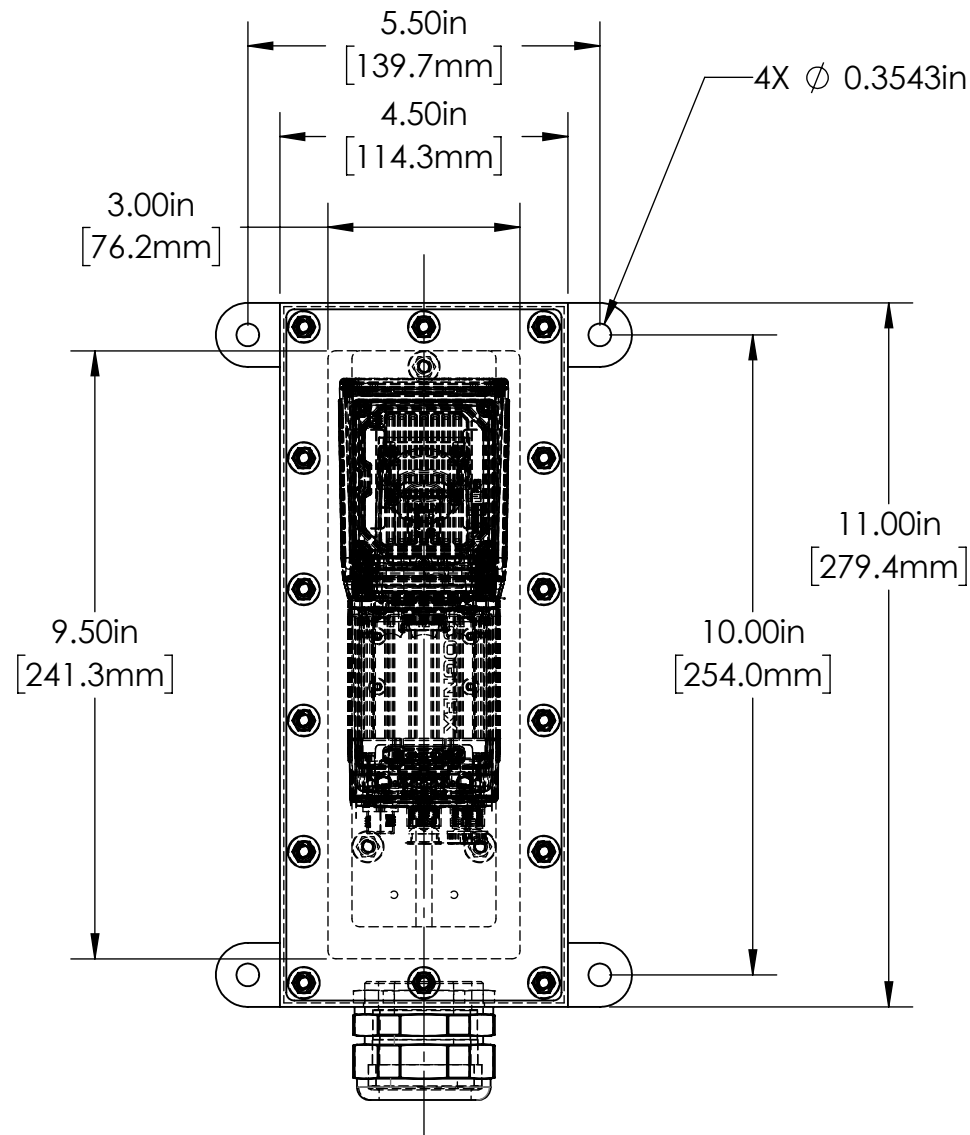

LD SERIES PROPERTIES TABLE

ENVIRONMENT RATING	IP69K*	
	(*RATING MAY CHANGE IF INSTALLER MILLS CABLE GLAND OUTSIDE OF TOLERANCE)	
COMPONENT	MATERIAL	FINISH
BODY	316 SS	BURNISHED
VIEWPORT	CLEAR FLOW COAT ACRYLIC	ABR2
GASKET	SILICONE	NONE
ARM/ADAPTOR	6061 ALUMINUM	NONE
HARDWARE	316 SS - EXTERNAL, 18-8 SS - INTERNAL	NONE

TOLERANCES UNLESS OTHERWISE SPECIFIED			
MACHINING		SHEET METAL	
X.X	0.0250"	HOLE TO HOLE (SAME SURFACE)	
X.XX	0.0100"	X.X	0.030"
X.XXX	0.0050"	X.XX	0.010"
X.XXXX	0.0005"	X.XXX	0.005"
ANGULAR	0.5°	X.XXX	0.015"
DEBURR ALL		HOLE TO FOLDED EDGE	
		X.X	0.035"
		X.XX	0.025"
		X.XXX	0.015"
		FOLD TO FOLD	
		X.X	0.045"
		X.XX	0.035"
		X.XXX	0.020"
		ANGULAR 1.0°	

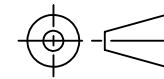

THIS PRINT IS THE PROPERTY OF APG VISION LLC. THE INFORMATION CONTAINED HEREIN IS CONFIDENTIAL. IT IS NOT TRANSFERABLE. IT IS FURNISHED WITH THE CLEAR UNDERSTANDING THAT IT IS NOT TO BE TRACED, REPRODUCED OR USED IN ANY PROCESS OF MANUFACTURING WITHOUT WRITTEN PERMISSION FROM THE OWNER AND IS RETURNABLE UPON DEMAND. ANY INFRINGEMENT UPON THE PATENT RIGHTS SHOWN HEREIN, WHETHER IN PART OR WHOLE, WILL BE PROSECUTED.

AS PART OF OUR POLICY OF CONTINUING DEVELOPMENT, APG VISION LLC RESERVES THE RIGHT TO ALTER SPECIFICATIONS WITHOUT PRIOR NOTICE.

APG Vision LLC
4055 Alpha Drive
Allison Park, PA 15101 USA
Phone +1 (412) 487-8211
apgvision.com



DESCRIPTION:
LD IP69K ENCLOSURE FOR COGNEX DM470 HSSM MIRROR WITH PROVISIONS FOR HEATER & THERMOSTAT

MATERIAL: SEE BOM

FINISH: SEE BOM

DRAWN BY: DMM DATE: 12/7/2021 SCALE: 1:3 SHT-SIZE: B APPROX. WEIGHT (LBS): 5.2661

CHECKED BY: DMM DATE: 12/7/2021 PART NUMBER: LD-FP REVISION: A

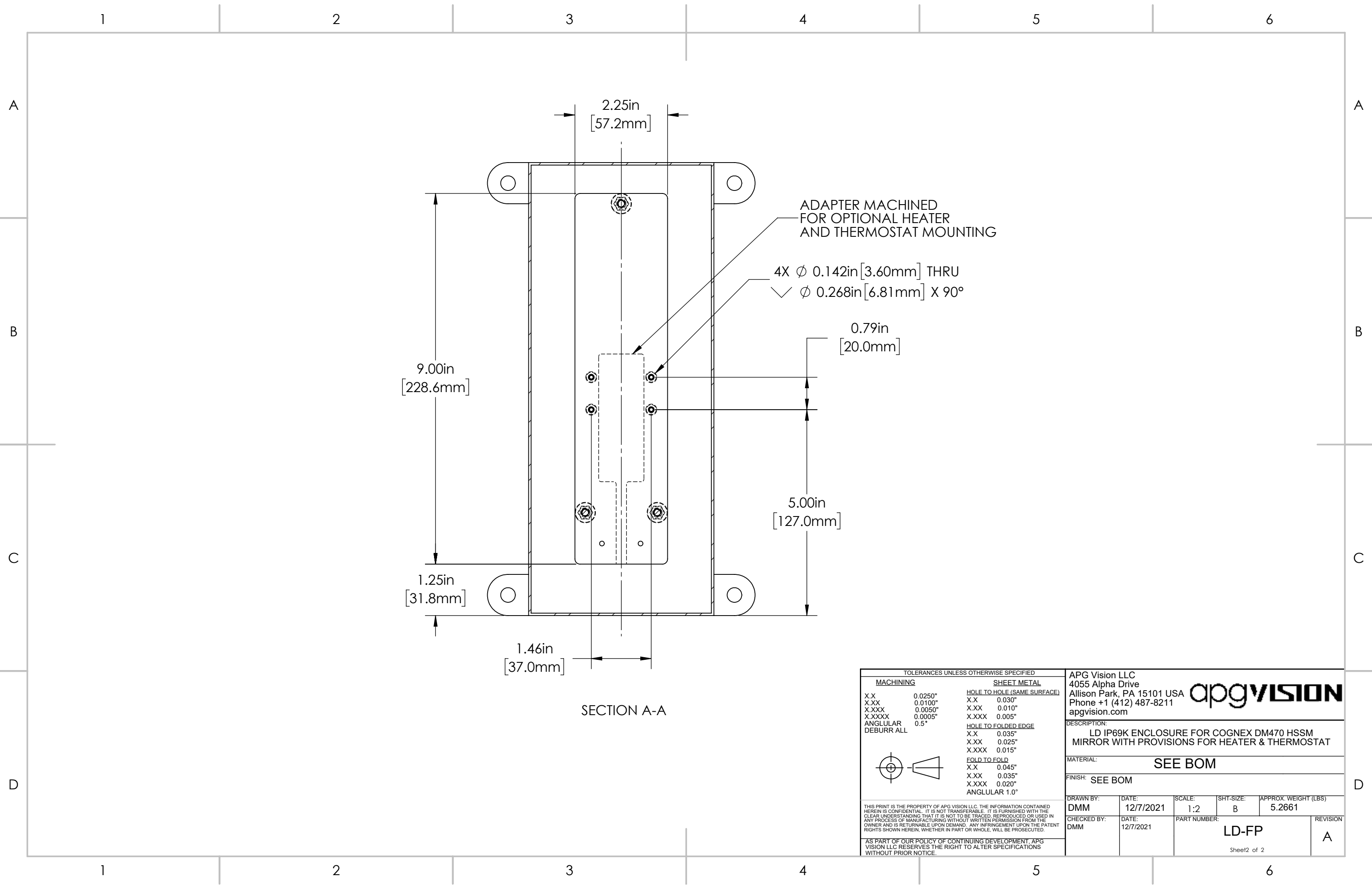

ADAPTER MACHINED FOR OPTIONAL HEATER AND THERMOSTAT MOUNTING

4X ϕ 0.142in [3.60mm] THRU
 \surd ϕ 0.268in [6.81mm] X 90°

0.79in [20.0mm]

5.00in [127.0mm]

9.00in [228.6mm]

1.25in [31.8mm]

1.46in [37.0mm]

SECTION A-A

TOLERANCES UNLESS OTHERWISE SPECIFIED			
MACHINING		SHEET METAL	
X.X	0.0250"	HOLE TO HOLE (SAME SURFACE)	
X.XX	0.0100"	X.X	0.030"
X.XXX	0.0050"	X.XX	0.010"
X.XXXX	0.0005"	X.XXX	0.005"
ANGULAR	0.5°	HOLE TO FOLDED EDGE	
DEBURR ALL		X.X	0.035"
		X.XX	0.025"
		X.XXX	0.015"
		FOLD TO FOLD	
		X.X	0.045"
		X.XX	0.035"
		X.XXX	0.020"
		ANGULAR 1.0°	

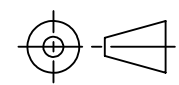

THIS PRINT IS THE PROPERTY OF APG VISION LLC. THE INFORMATION CONTAINED HEREIN IS CONFIDENTIAL. IT IS NOT TRANSFERABLE. IT IS FURNISHED WITH THE CLEAR UNDERSTANDING THAT IT IS NOT TO BE TRACED, REPRODUCED OR USED IN ANY PROCESS OF MANUFACTURING WITHOUT WRITTEN PERMISSION FROM THE OWNER AND IS RETURNABLE UPON DEMAND. ANY INFRINGEMENT UPON THE PATENT RIGHTS SHOWN HEREIN, WHETHER IN PART OR WHOLE, WILL BE PROSECUTED.

AS PART OF OUR POLICY OF CONTINUING DEVELOPMENT, APG VISION LLC RESERVES THE RIGHT TO ALTER SPECIFICATIONS WITHOUT PRIOR NOTICE.

APG Vision LLC
 4055 Alpha Drive
 Allison Park, PA 15101 USA
 Phone +1 (412) 487-8211
 apgvision.com



DESCRIPTION:
 LD IP69K ENCLOSURE FOR COGNEX DM470 HSSM MIRROR WITH PROVISIONS FOR HEATER & THERMOSTAT

MATERIAL: SEE BOM

FINISH: SEE BOM

DRAWN BY: DMM	DATE: 12/7/2021	SCALE: 1:2	SHT-SIZE: B	APPROX. WEIGHT (LBS): 5.2661
------------------	--------------------	---------------	----------------	---------------------------------

CHECKED BY: DMM	DATE: 12/7/2021	PART NUMBER: LD-FP	REVISION: A
--------------------	--------------------	-----------------------	----------------