

1 2 3 4 5 6

A A

B B

C C

D D

REVISIONS				
ZONE	REV.	DESCRIPTION	DATE	APPROVED
	A	RELEASED FOR PRODUCTION	3/28/2022	DMM

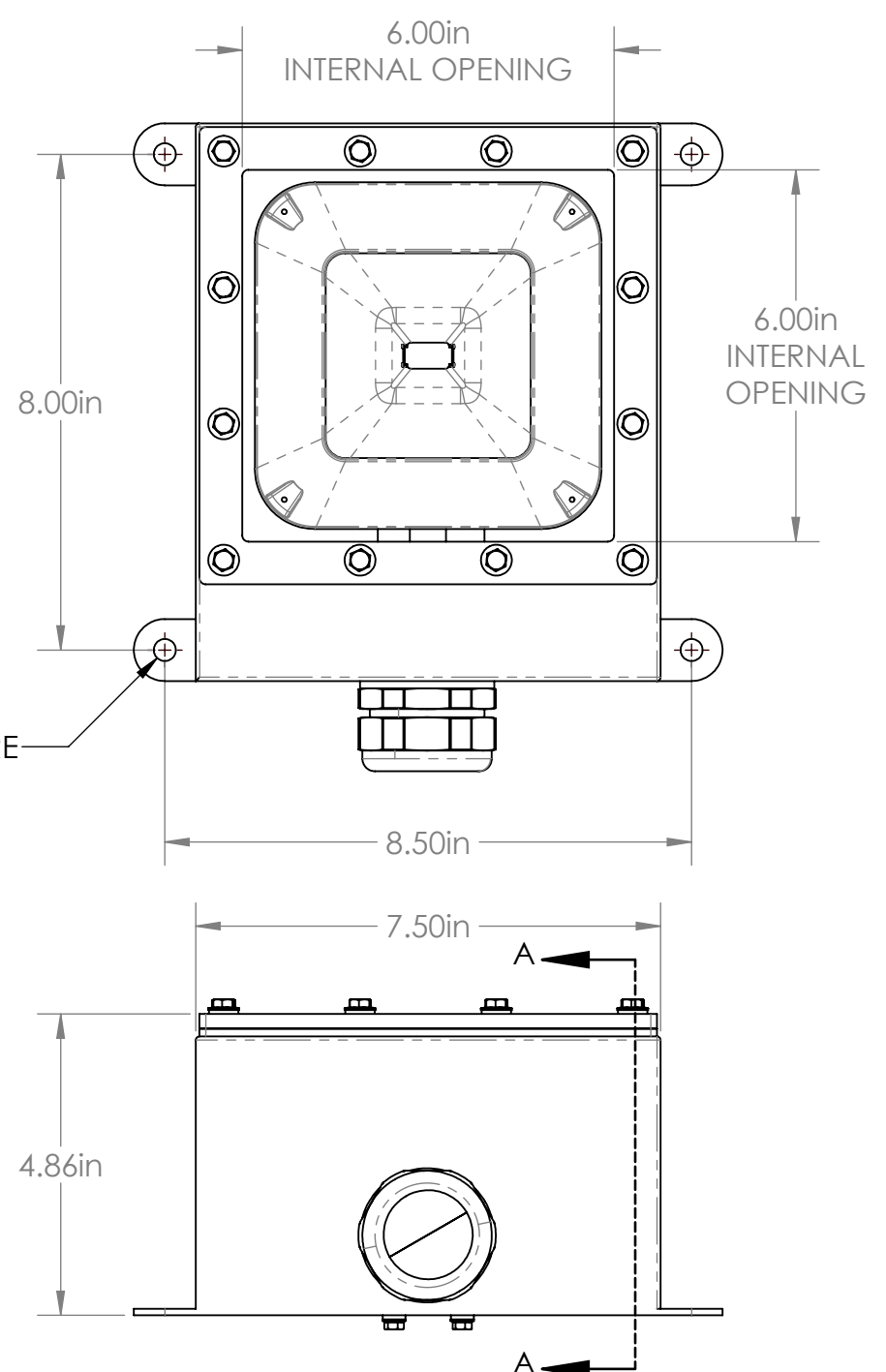

USE M8 OR 5/16"  
MOUNTING HARDWARE

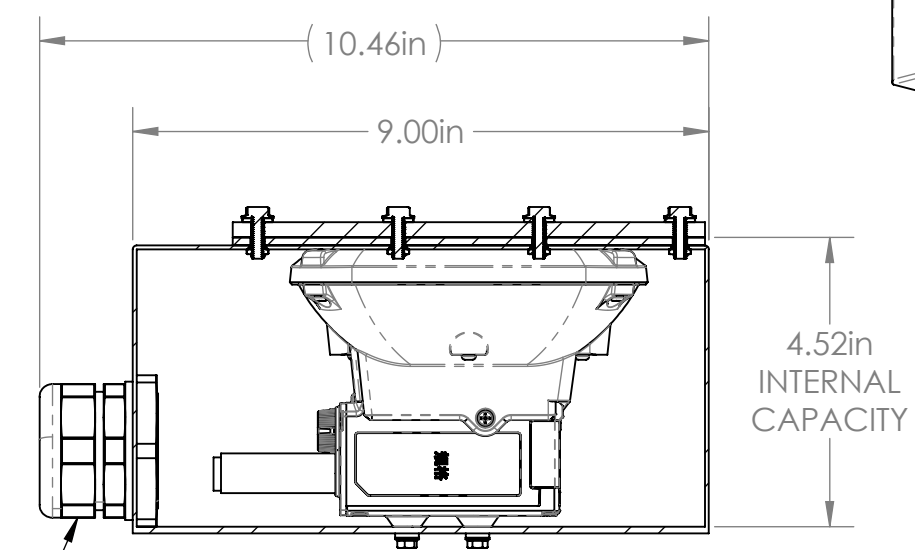
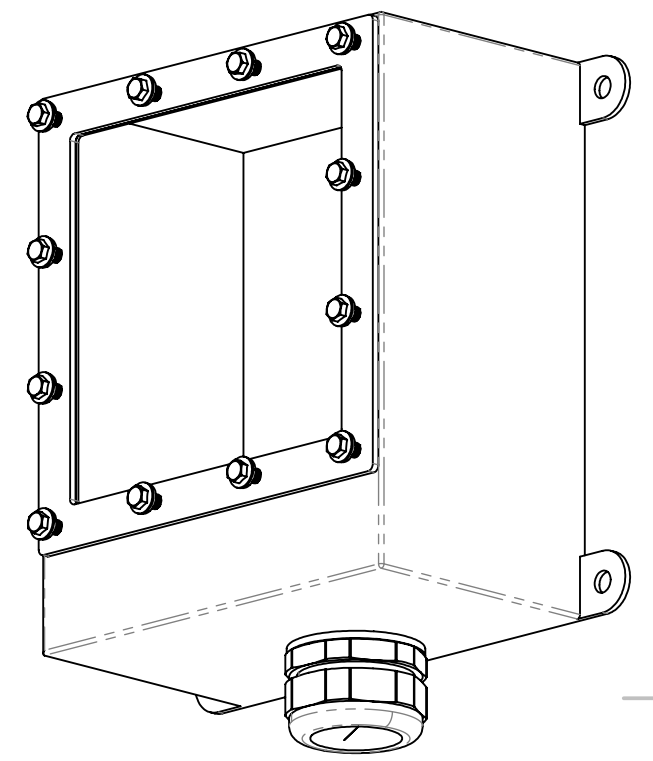

SECTION A-A

PG36 CORD GRIP

**PROPERTIES TABLE**

ENVIRONMENT RATING	IP69K*	FDA WASHDOWN
	(*RATING MAY CHANGE IF INSTALLER MILLS CABLE GLAND OUTSIDE OF TOLERANCE)	
COMPONENT	MATERIAL	FINISH
BODY	316 SS	BURNISHED
VIEWPORT	CLEAR FLOW COAT ACRYLIC	ABR2
GASKET	SILICONE	NONE
HARDWARE	316 SS	AS SUPPLIED

TOLERANCES UNLESS OTHERWISE SPECIFIED

MACHINING		SHEET METAL	
X.X	0.0250"	HOLE TO HOLE (SAME SURFACE)	
X.XX	0.0100"	X.X	0.030"
X.XXX	0.0050"	X.XX	0.010"
X.XXXX	0.0005"	X.XXX	0.005"
ANGULAR	0.5°	HOLE TO FOLDED EDGE	
DEBURR ALL		X.X	0.035"
		X.XX	0.025"
		X.XXX	0.015"
		FOLD TO FOLD	
		X.X	0.045"
		X.XX	0.035"
		X.XXX	0.020"
		ANGULAR 1.0°	

THIS PRINT IS THE PROPERTY OF APG VISION LLC. THE INFORMATION CONTAINED HEREIN IS CONFIDENTIAL. IT IS NOT TRANSFERABLE. IT IS FURNISHED WITH THE CLEAR UNDERSTANDING THAT IT IS NOT TO BE TRACED, REPRODUCED OR USED IN ANY PROCESS OF MANUFACTURING WITHOUT WRITTEN PERMISSION FROM THE OWNER AND IS RETURNABLE UPON DEMAND. ANY INFRINGEMENT UPON THE PATENT RIGHTS SHOWN HEREIN, WHETHER IN PART OR WHOLE, WILL BE PROSECUTED.

AS PART OF OUR POLICY OF CONTINUING DEVELOPMENT, APG VISION LLC RESERVES THE RIGHT TO ALTER SPECIFICATIONS WITHOUT PRIOR NOTICE.

APG Vision LLC  
4055 Alpha Drive  
Allison Park, PA 15101 USA  
Phone +1 (412) 487-8211  
apgvision.com

**apgvision**

DESCRIPTION:  
**CUSTOM SEALED ENCLOSURE FOR KEYENCE SR-2000+SR-20AL**

MATERIAL: **SEE PROPERTIES TABLE**

FINISH: **SEE PROPERTIES TABLE**

DRAWN BY: DMM	DATE: 3/28/2022	SCALE: 1:3	SHT-SIZE: B	APPROX. WEIGHT (LBS): 7.1057
CHECKED BY: DMM	DATE: 3/28/2022	PART NUMBER: <b>LD-FS</b>	REVISION: <b>A</b>	

Sheet 1 of 1

1 2 3 4 5 6