

Ø0.33in
[8.3mm]
MOUNTING HOLE

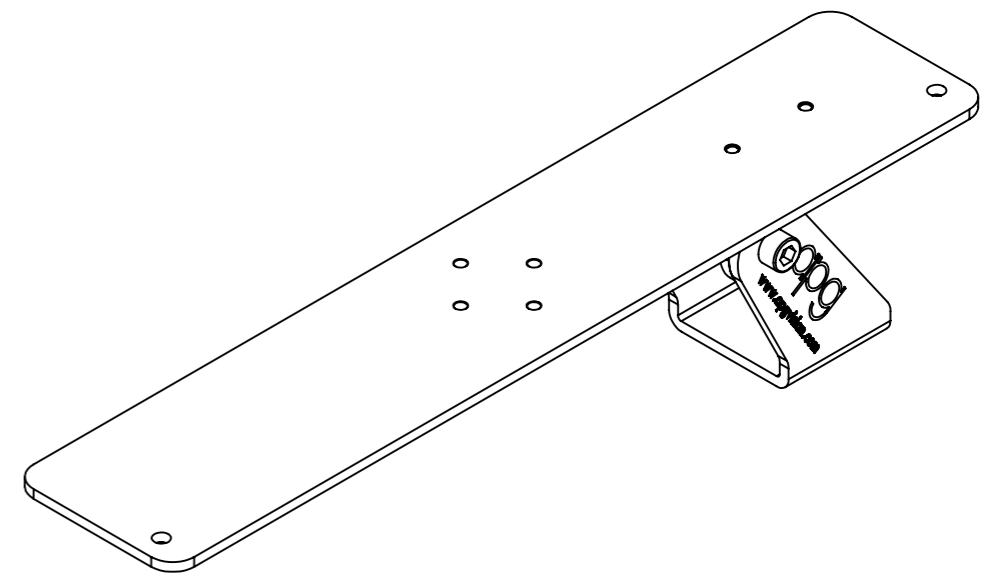

NOTE: STAINLESS STEEL BASE CAN ALSO BE CENTER MOUNTED WITH TILT EITHER PARALLEL TO OR 90 DEGREES TO LIGHT AXIS

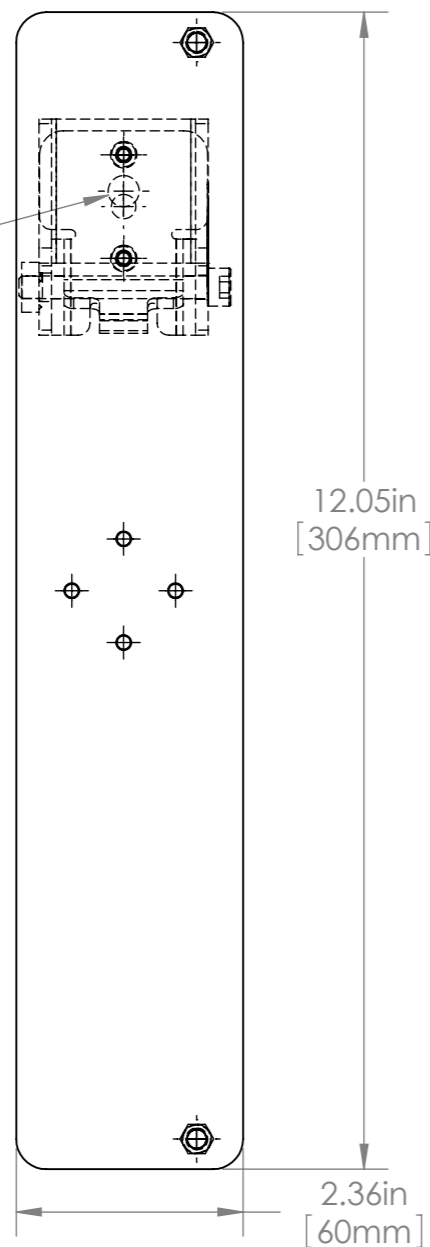
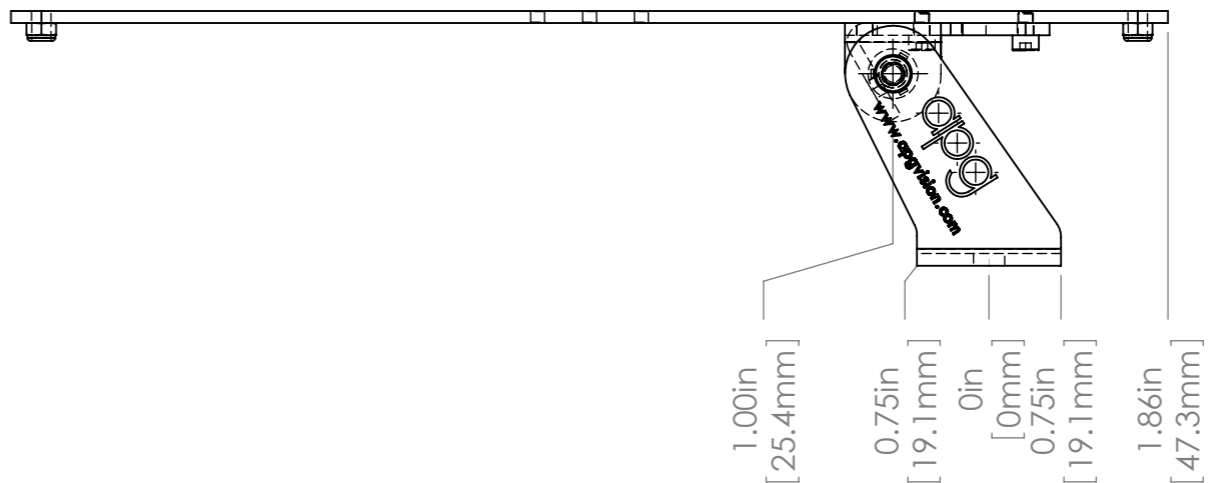
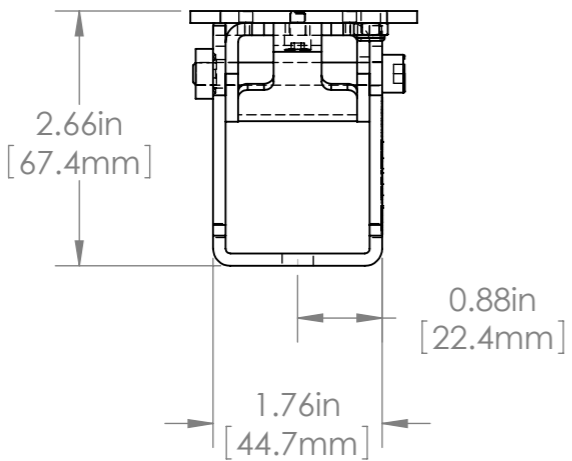

				UNLESS OTHERWISE SPECIFIED: DIMENSIONS ARE IN INCHES SURFACE FINISH: TOLERANCES: .000= +/- 0.005" .00= +/- 0.010"		FINISH: DEBUR AND BREAK SHARP EDGES		Allison Park Group, Inc. (APG) 4055 Alpha Drive Allison Park, PA 15101 USA		DO NOT SCALE DRAWING		REVISION	
				LINEAR:				Phone +1 (412) 487-8211 Fax +1 (412) 486-3157		This document is the property of APG and is considered company confidential. The information in this document is the property of APG and may not be used, reproduced, or distributed in whole or in part without the prior written permission of APG.			
				DRAWN		NAME		SIGNATURE		DATE		TITLE:	
				SCHUBERT						7/26/2010		PTU-LB ASSY DIMS	
				CHK'D									
				APPV'D									
				MFG									
				Q.A									
				NOTES:									
				MATERIAL:				316 STAINLESS STEEL BASE ALUINUM LIGHT MOUNT		DWG NO.		PTU-LB	
				NO.		CHANGE		DATE		INIT.		A3	
				WEIGHT:						SCALE:1:5		SHEET 1 OF 1	