

ToughEye-3100™ Spec Sheet

Version 2.0

The ToughEye-3100™ line of cameras provide industry leading, zero maintenance¹, self-cleaning operation, suitable for any industrial application where a clear view is critical to the success of the operation. ToughEye-3100™ incorporates a field-proven rugged single-piece design, equipped with our innovative ClearSight™ technology. The ToughEye™ family of cameras excel at three things: **reliability**, **zero-maintenance operation** and **image clarity**. All ToughEye-3100™ cameras feature both analog and IP video outputs.



ExcelSense can customize ToughEye-3100™ installations for almost any application. Please enquire with admin@apgvision.com

SPECIFICATIONS

CAMERA

| | |
|-----------------------|---|
| Image Sensor | 2.34 MP |
| Resolution (HxV) | 2000 x 1241 |
| Min Illumination | 0.1Lux/F2.0 (No illumination required for IR/Visible version) |
| Illumination Distance | Infrared option: 15m [50'] est Visible option: 5m [16'] est |
| Horizontal FoV | 80°, 120° |
| Video (IP) | H.264 (1920x1080) MJPEG (1280x720) |
| Video (Analog) | 720x486 (NTSC), 720x576 (PAL) |
| Network | RTSP, RTP, UDP, RTCP, IGMP, HTTPS |
| ONVIF | Profile S |
| Recording | 32GB Storage - Continuous, Motion |

PHYSICAL

| | |
|------------------------|--|
| Dimensions | 297mm x 170mm x 130mm [11.7in x 6.7in x 5.1in] (Extended) |
| | 241mm x 170mm x 130mm [9.5in x 6.7in x 5.1in] (Retracted) |
| Weight | ToughEye-3100™: 5.9kg [13lbs] Standard bracket: 2.3kg [5lbs] |
| Clean Cycle | Configurable Timer Based, Electrical Trigger (Up to 24V) |
| | Extension Time 3sec (typ). Full Cycle Time 10sec (max) |
| | Rated cycles: 60000 or 90000 (see ordering options) |
| Max Wattage (Ext Temp) | 96W |
| Input Voltage | 24V |
| Temp Range | -40°C to 50°C (Extended Temp) |
| | 5°C to 50°C (Non-extended Temp) |
| IP Rating | IP68 |
| Vibration | Tested to 11g |

MECHANICAL DRAWING

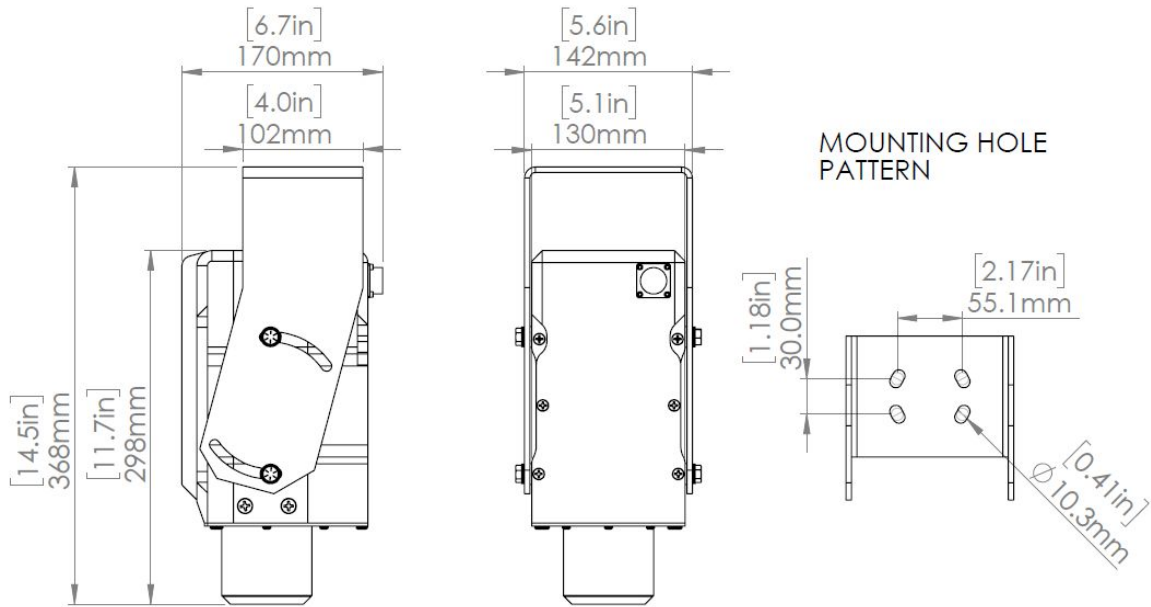

Note: Mounting bracket with dampers available for extreme vibration environments such as hard-rock drilling rigs and continuous miners.

ORDERING OPTIONS

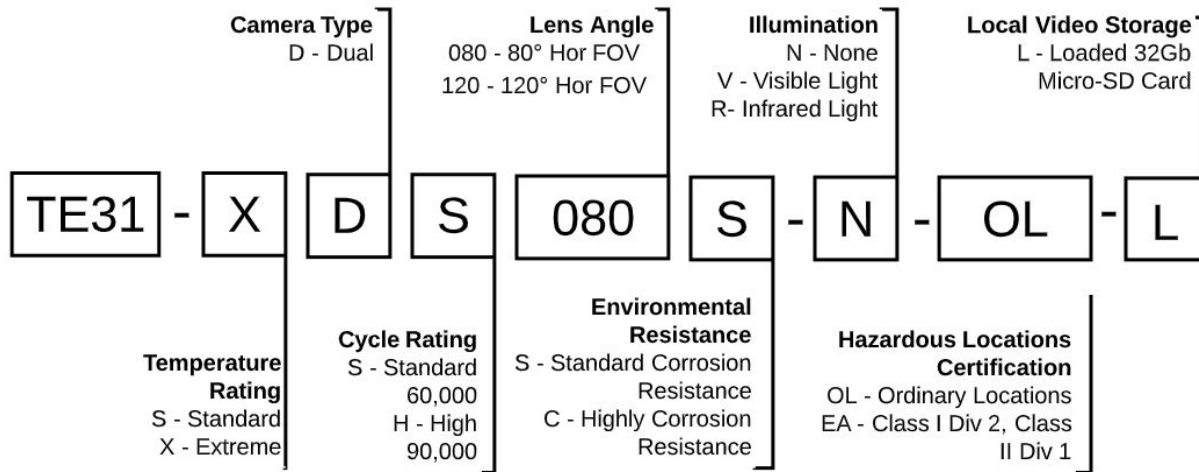

TE31 - ToughEye-3100™ camera

Lens Angle

080 - 80° Horizontal FOV
120 - 120° Horizontal FOV

Temperature Rating

S - Standard: 5 °C to 50 °C
X - Extreme: -40°C to 50°C

Environmental Resistance

S - Standard corrosion resistance
C - High corrosion resistance

Camera Type

D - Dual: IP / Analog Camera

Illumination

N - None: No illumination
V - Visible Light LED array
R - Infrared Light LED array

Cycle Rating

S - Standard: Rated for 60,000 cycles
H - High: Rated for 90,000 cycles

Hazardous Locations Certification

OL - Ordinary locations
EA - Class I Div 2, Class II Div 1 Certified

Local Video Storage

L - Loaded 32Gb Micro-SD Card

ACCESSORIES

The following lists standard accessories available for ToughEye-3100™ installations.

MAIN CABLE

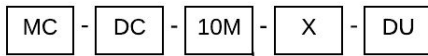
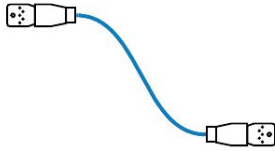

Length
XXM - XX meter

Main cable used in all ToughEye installations.
Available in: **3m, 5m, 10m, 15m, 20m, 22m, 25m, 30m** lengths

EXTENSION CABLE

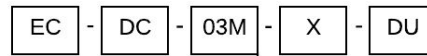
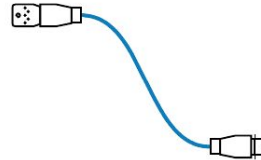

Length
XXM - XX meter

Extension cables can be used to increase the length of existing cables. Available in: **3m, 10m** lengths

BREAKOUT CABLE

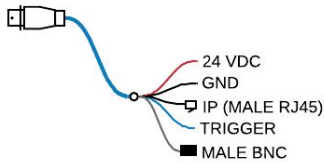

Breakout cable providing access to the internal connections of the ToughEye. Typically terminated through a cable gland into an existing electrical cabinet. Comes standard with **1m** length.

POWER CABLE

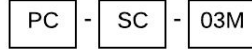
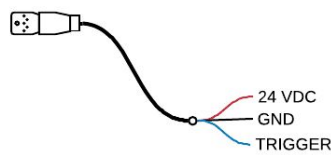

The power cable is used to power the dual output junction box (PN JB-DU-AM-1C). Typically terminated through a cable gland into an existing electrical cabinet. Comes standard with **3m** length.

SEALED RJ45 KIT

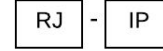

For use with the dual output junction box (PN JB-DU-AM-1C). Allows for an IP rated network connection. CAT 5e or better cable required



**DUAL OUTPUT
JUNCTION BOX**

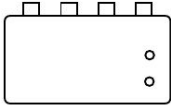

JB - DU - AM - 1C

Standard dual output junction box. Suitable for outdoor installation. Provides connections for ToughEye, Input Power, Network and compatible with ExcelSense standard 7" Monitor (PN AM-3C-7IN-MB)

**7" MONITOR WITH
MOUNT**

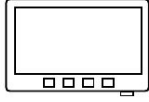

AM - 3C - 7IN - MB

7" Monitor with included adjustable mount. Can be connected directly to the dual output junction box (PN JB-DU-AM-1C)

**MIL-SPEC
MOBILE NVR**



NVR - MIL - 4C

Network video recorder intended for harsh mobile applications. When combined with one or more ToughEye cameras it allows for extended storage capacity and remote triggering capability

**WELDING ADAPTER
BRACKET**

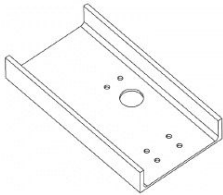

MB - TE - WE

Suitable for welding to existing horizontal or vertical surfaces when bolting is not an option

**PROGRAMMING
CABLE**

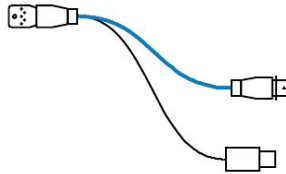

PA - TE - USB - A

Programming cable is used to modify timing of automatic cleaning cycles, retrieving cleaning cycle data and for updating internal microcontroller firmware. Suitable for inline connection to ToughEye

TYPICAL INSTALLATION

Several common configurations for ToughEye-3100™ are shown. Many other configurations are possible, please contact admin@apgvision.com with your specific requirements and we will make it happen.

Further details on these configurations and the accessories used can be found in the ToughEye-3100™ user manual.

Breakout Cable

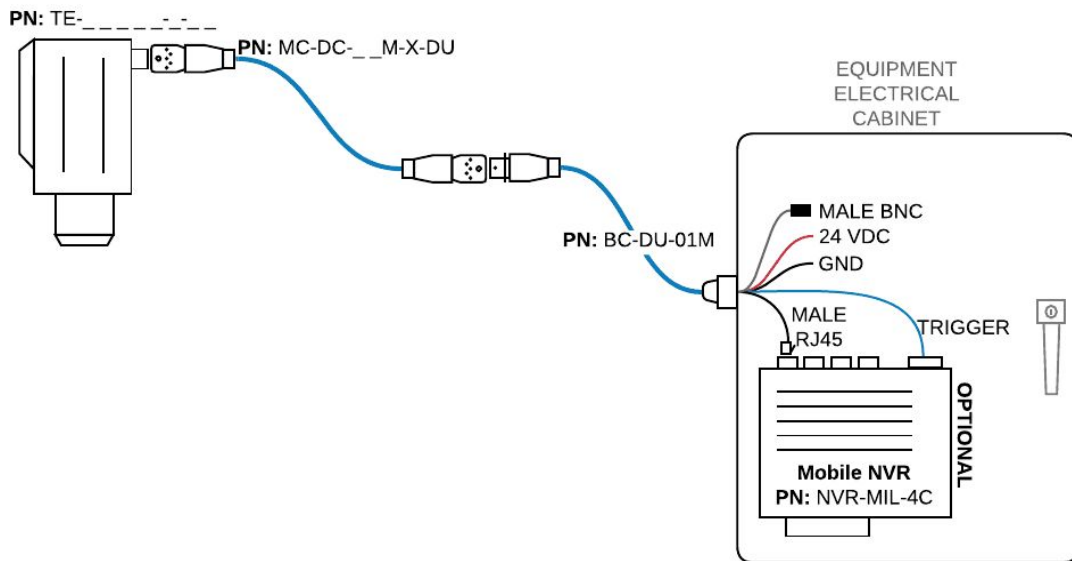

Typical Usage

Any equipment or location which needs remote monitoring. This configuration is the simplest to install and provides limitless options for any number of cameras. It requires a 24 VDC Class 2 power supply and a router or access point for network connectivity. The trigger can be connected to any digital switch to initiate cleaning of the camera. Alternatively the camera can be configured for timer based cleaning.

This configuration is also suitable for connection of the analog signal to an existing monitor or existing analog frame-grabber.

An optional mobile NVR can provide several advantages including: remote triggering, extended video storage and the potential to map multiple ToughEye-3100™ cameras to a single IP.

TYPICAL INSTALLATION

In-Cab Monitor

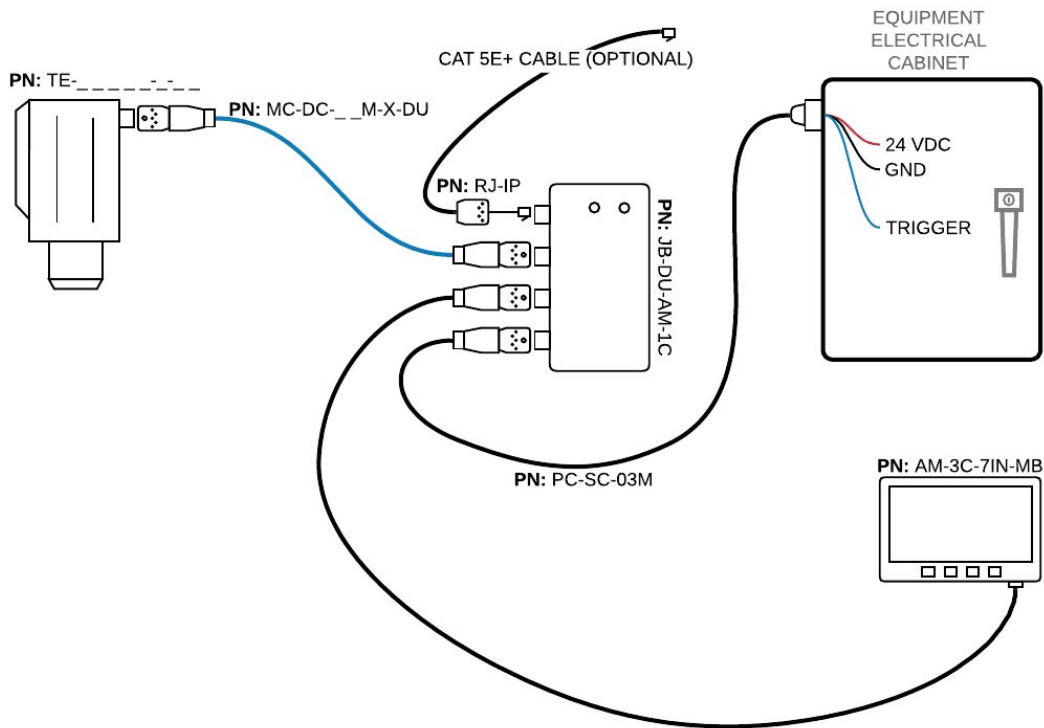

Typical Usage

Any heavy duty equipment where a clearly visible view is required by the machine operator. It requires a 24 VDC Class 2 power supply. The self-clean trigger is commonly attached to the reverse gear of mobile equipment, for rear facing cameras. Alternatively, the self-clean trigger can be attached to a physical button or the ToughEye-3100™ can be configured to clean at regular intervals.

Monitor supports up to 3 channels, suitable junction box and cabling is available.