



## Industrial Enclosures for:

- Cameras • Lighting
- Pan & Tilt Mounts
- Custom Applications



# Industrial Enclosures for Harsh Environments

User Manual

Series 22C, 24C, 35C, 47C

Allison Park Group, Inc.

4055 Alpha Drive, Allison Park, PA 15101

[www.apgvision.com](http://www.apgvision.com)

412.487.8211

# Introduction

Developed and tested by APG Inc., this enclosure was designed to protect your device(s) in harsh, industrial environments. Follow this guide for instructions on assembling and maintaining the enclosure while ensuring the performance of the integrated component.

## Protection Rating

Our **24C, 35C, and 47C Series** enclosures are rated **NEMA 4 / IP65**, guaranteed to be dust proof as well as protecting against low-pressure spray downs. These enclosures are constructed with an anodized 6061 aluminum and fastened with 18-8 stainless steel.

For a lower cost option our **22C Series** enclosures are rated **NEMA 12 / IP52**; constructed for indoor use these enclosures protect against personnel contact with the enclosed equipment, are dust protected, and protect against mild splashes.

All gaskets are made from a silicone rubber, Viton™ rubber, or EPDM foam. The viewport window may be a clear acrylic with a scratch-resistant coating applied to either side, glass, or clear polycarbonate.

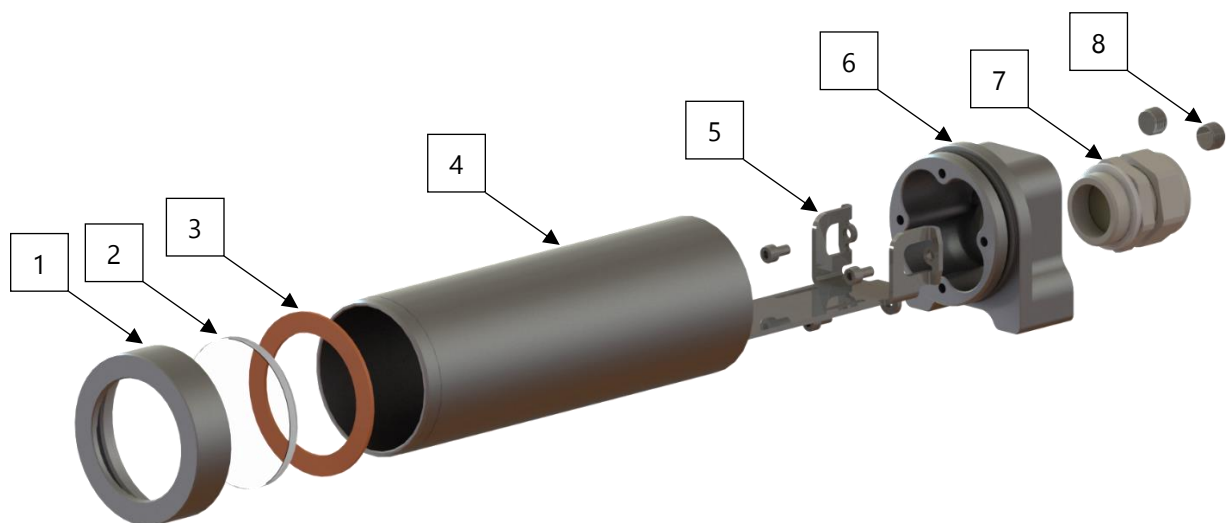

Note: Enclosure Bodies differentiate between 22C, 24C, and 35C/47C Series enclosures. Mounting Arms will fasten to the 22C, 24C, and 35C/47C Series Enclosure Bodies differently.

ITEM NO.	DESCRIPTION
1	FACEPLATE
2	VIEWPORT / WINDOW
3	FACEPLATE GASKET
4	BARREL
5	MOUNTING ARM
6	ENCLOSURE BODY
7	CORD GRIP
8	AIR FITTING PLUG(S)

# Installation Instructions

1. You may need the following tools:
  - a. Miniature strap wrench or pliers (Non-marking jaws suggested)
  - b. 1/8" Hex Key
  - c. 3/16" Hex Key
  - d. 1/4" Hex Key
  - e. 11/16" Box end wrench or deep socket
  - f. 3/4" Box end wrench or deep socket
2. Preparing the enclosure:
  - a. Unscrew the Barrel from the Enclosure Body by hand.

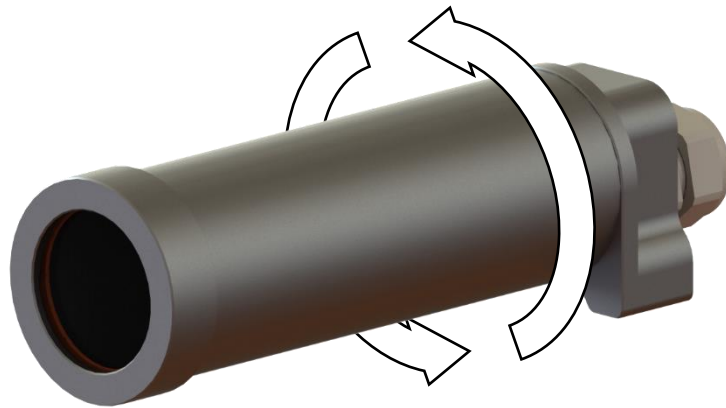

3. Mounting your enclosure:

a. 22C Series

- i. Four (4) M5x0.8, 0.325" deep mounting holes are located on each side of the Enclosure Body.

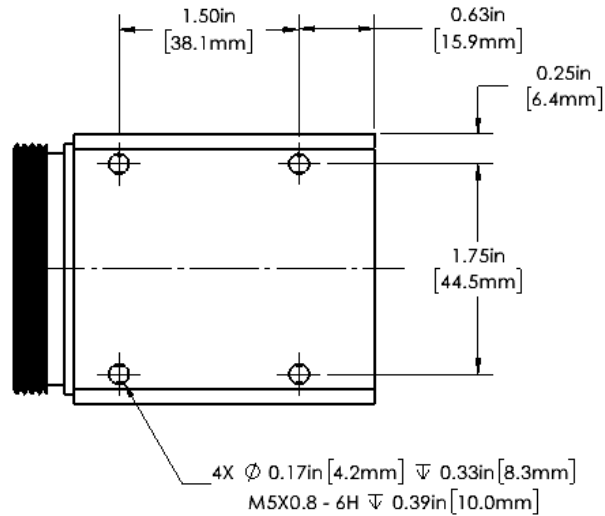

- ii. Contact our Sales team to ask about a Pan & Tilt mounting adapter for your enclosure.
- iii. Skip to Step 4 to continue installing your enclosure.

b. 24C Series

- i. Four (4) M5x0.8, 0.50" deep mounting holes are located on the Enclosure Body.

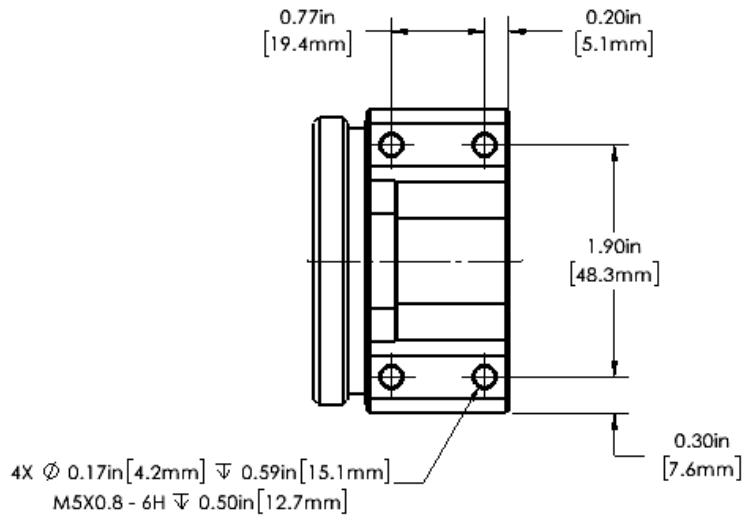

- ii. Contact our Sales team to ask about a Pan & Tilt mounting adapter for your enclosure.
- iii. Skip to Step 4 to continue installing your enclosure.

### c. 35C Series

- i. Your enclosure includes a Pan & Tilt mounting base that will allow you to pitch, yaw, and roll your enclosure to a preferred position before securing in place.

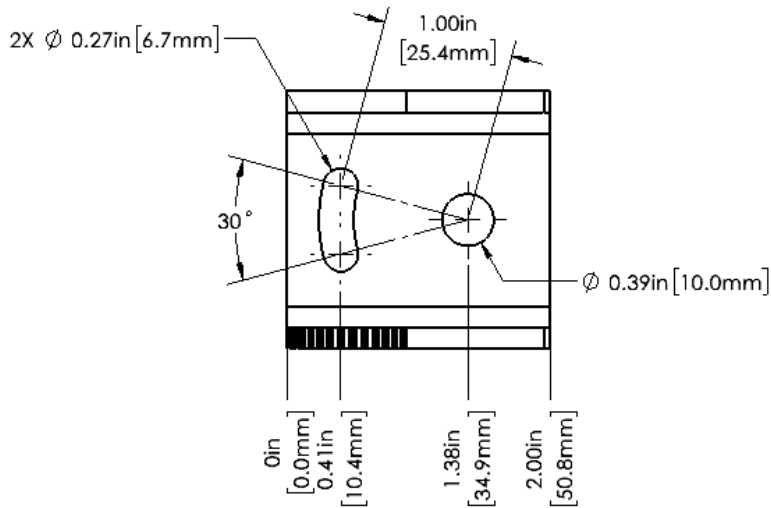

- ii. Skip to Step 4 to continue installing your enclosure.

### d. 47 Series

- i. Your enclosure includes a Pan & Tilt mounting base that will allow you to pitch, yaw, and roll your enclosure to a preferred position before securing in place.

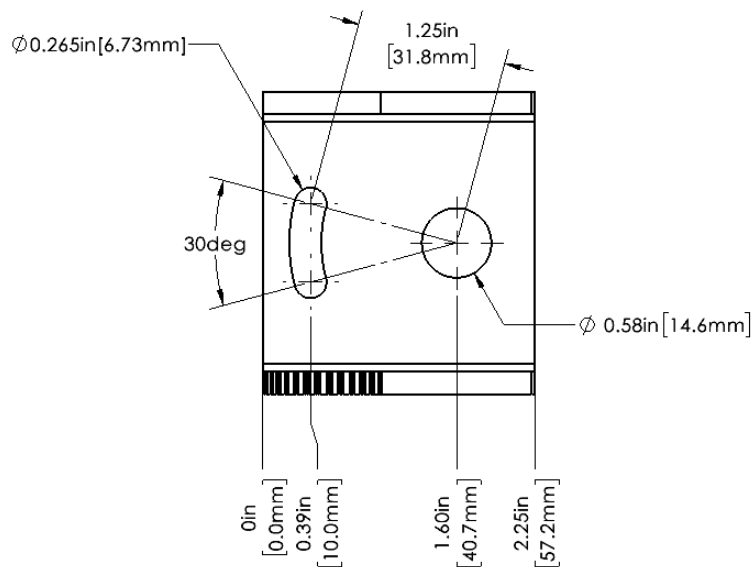

- ii. Skip to Step 4 to continue installing your enclosure.

4. Installing your component(s) into the enclosure:
  - a. It may be helpful to run your device's cable(s) into the enclosure through the Cord Grip before mounting the device into the enclosure.
  - b. Align the mounting holes on your device with the hole cutouts on the enclosure Mounting Arm.
  - c. Secure your device to the Mounting Arm using the fasteners provided with your device or the optional bolts included with the enclosure.

Note: If the Mounting Arm for your enclosure has slot cutouts, use these to position the lens of your camera or sensor as close to the Viewport as possible to avoid reflections.

5. Refer to the Cable Gland Instructions at the end of this manual for proper milling of Cable Gland Insert and cable(s) installation.
6. Sealing the enclosure:
  - a. With your component(s) installed in the enclosure, reinstall the barrel that you removed in Step 2.
  - b. **Hand tightening** the Faceplate, Barrel, and Enclosure Body together will be enough to seal your enclosure and meet its IP rating. Threads will be pre-lubricated to keep the seal.

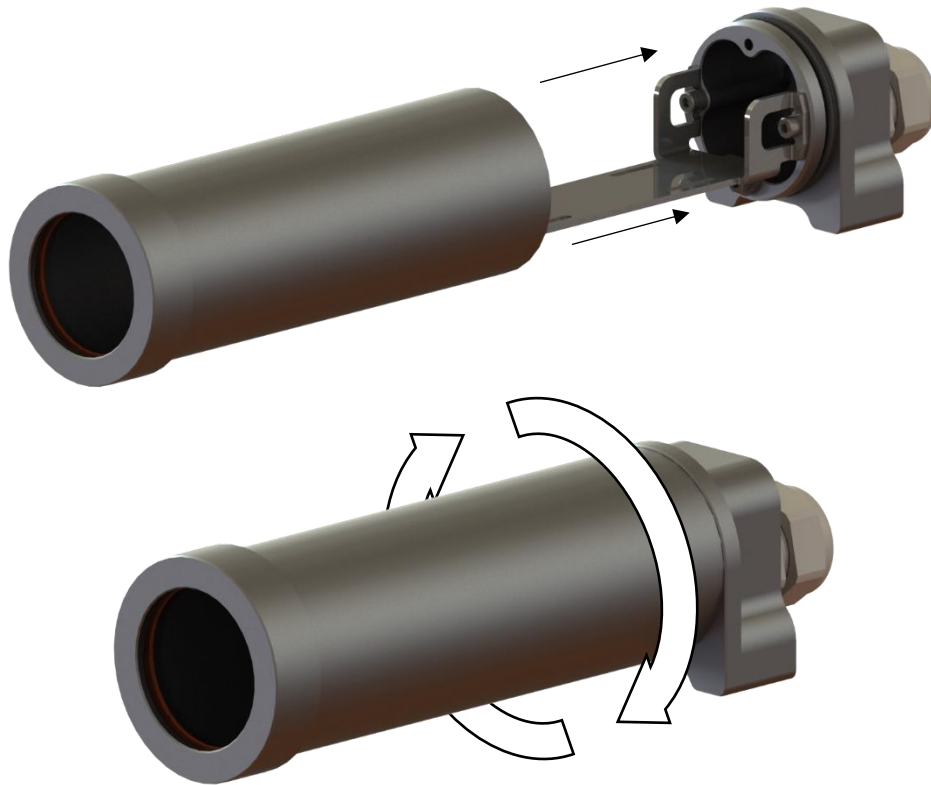

# Air-Cooling the Enclosure

This assembly option includes adapters and gaskets to allow your enclosure to be cooled with supplied air.

Note: If you are not installing the optional Air Curtain feature, skip to Step 5 of this section.

1. By hand, unscrew the Faceplate from the Barrel.
2. Remove the Faceplate Gasket from the Faceplate.
3. Install the optional Air Curtain gasket into the Faceplate so that it sits against the Viewport.
  - a. Reference the exploded view on Page 2.
4. By hand, reinstall the Faceplate onto the Barrel.

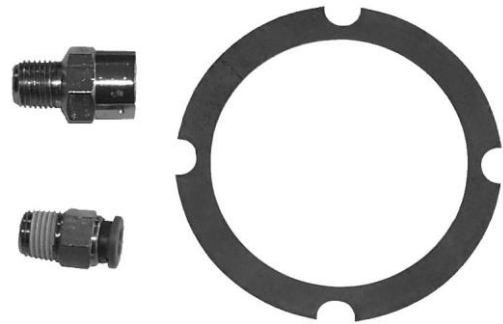

Note: With an Air Curtain Gasket the enclosure will become unsealed. If maintaining the seal and air blow-off is desired, ask our sales team about our *Air Shield* faceplate option.

5. Using a hex key wrench, remove the Air Fitting Plugs that came installed on back of the Enclosure Body.
6. Using a socket or an adjustable wrench, install one or both Air Fitting Adapters into the threaded holes as necessary.
7. Recommended supply air pressure is **2-5 PSIA (0.138-0.345 Bar)**.
  - a. Make sure air is clean and dry. Long air lines can accumulate moisture in humid environments.



# Enclosure Accessories

Our 22C, 24C, 35C, and 47C enclosures have optional accessories available to improve their protection capacity.

## *Sun Shield / Heat Shield*

If your equipment needs additional protection from bright lights or radiating heat, then our Sun Shield may be the right choice for your enclosure. The Sun Shield may be easily installed by positioning it onto your enclosure and securing it in place with the Sun Shield's included clamps.



## *Air Shield Faceplate*

If the Air Curtain Gasket included with your enclosure is not sufficiently clearing the debris or moisture from the viewport of your enclosure, then our *Air Shield* faceplate may be the right choice for your enclosure. It provides a high velocity, thin sheet of air across the viewport.



1. By hand, unscrew the existing Faceplate from the Barrel.
2. Remove the Faceplate Gasket and Viewport from the Faceplate.
3. Install the Faceplate Gasket and Viewport into the *Air Shield* Faceplate.
4. By hand, install the Air Shield Faceplate onto the Barrel.
5. Connect your preferred air fitting into the 1/8 NPT tapped hole on the side of the *Air Shield* Faceplate.
6. The Air Knife Faceplate is designed to use normal shop air supplies up to 100 PSIG (6.9 Bar).
  - a. Make sure air is clean and dry. Long air lines can accumulate moisture in humid environments.





# Cleaning and Maintenance

## Stainless Steel:

When cleaning the stainless-steel body of your enclosure be sure to avoid bleach and cleaners with chlorine as these will stain and damage the surface. Additionally, steel wool and brushes should be avoided to preserve the polished finish.

## Aluminum:

Anodized aluminum parts may require abrasive cleaning with gentle cleaning products such as soap and water. Harsh cleaning products may react with unfinished aluminum parts.

## Acrylic / Polycarbonate:

Although your acrylic window comes with an anti-abrasion coating, it is important to routinely clean the surface to maintain visibility. APG recommends a plastic/acrylic cleaning solution, otherwise use soap and water with a microfiber towel.

DO NOT use ammonia, acetone, or alcohol-based cleaners; this will crack and weaken the acrylic.

## Glass:

It is important to routinely clean the surface of your enclosure's window to maintain visibility. For glass, make sure the surface is wet before cleaning to avoid scratching the surface. A microfiber towel is recommended for wiping down the surface when you are finished washing.

# Temperature Tolerance

The listed temperature ranges are for reference only. Exceeding these values may result in compromising the liquid tight enclosure and permanently damaging the material. Stainless Steel and Nickel-plated Brass Cable Gland Bodies are available if your application exceeds these materials' tolerances.

Polyethylene: -4° to 200° F  
EPDM Foam: -40° to 250° F  
Polycarbonate: -4° to 285° F  
TPE Split Insert: -20° to 285° F  
Viton™ Rubber: -20° to 400° F  
Silicone: -100° to 400° F

# Warranty Statement

Allison Park Group, Inc. (APG) warrants the equipment manufactured by it to be free from defects in materials and workmanship under normal use and service; its obligation under this warranty being limited to replacing at its facility any product, part, or parts which shall, within one (1) year after delivery of such equipment to the original purchaser, be returned, and which APG's examination shall disclose at its sole discretion to have been defective. This one (1) year warranty is forfeited by tampering, modifying, or altering the APG product in any way that is beyond the scope of provided instructions for routine inspection, care, and installation of integrated components. APG expressly disclaims any express or implied warranty of merchantability or fitness for a particular purpose. APG shall have no liability for damages, direct or consequential, on account of defective materials or workmanship. APG reserves the right to make changes in design, or to make additions to, or improvements in, its products without imposing any obligation upon itself to install them on its products previously installed. APG may provide assistance in the form of recommendations, engineering or technical information, and advice but such information is furnished only as an accommodation and APG shall have no liability for incomplete, faulty, or inaccurate advice, recommendations, or assistance, negligent or otherwise. APG accepts responsibility for the warranty of integrated components that are purchased and installed at its facility, subject to their terms and limitations. Returns or replacements of parts and/or products may be subject to shipping, handling, replacement, and/or restocking fees. Some regions do not allow limitations on how long an implied warranty lasts or allow exclusion or limitation of incidental or consequential damages, so the above limitations or exclusions may not apply to you. This warranty gives you specific legal rights, and you may also have other rights, which vary region to region.

# Fastener Torque Specifications

To properly fasten components of our enclosures, determine the fastener size (M5 or M6, typically) and the material of the gasket being compressed (Silicone, EDPM Foam, or Viton). Lubrication is applied to all tapped threads during assembly and reapplication is suggested if component is being reassembled.

## M5 Fasteners

- Silicone Gasket: 6.0 lb.in 0.6 N.m
- EDPM Foam Gasket: 4.0 lb.in 0.5 N.m
- Viton Gasket: 8.0 lb.in 0.9 N.m

## M6 and ¼ Inch Fasteners

- Silicone Gasket: 8.0 lb.in 0.9 N.m
- EDPM Foam Gasket: 4.0 lb.in 0.5 N.m
- Viton Gasket: 10.0 lb.in 1.1 N.m

## External Acrylic Viewport \*

- Silicone Gasket: 4.0 lb.in 0.5 N.m
- EDPM Foam Gasket: 4.0 lb.in 0.5 N.m
- Viton Gasket: 4.0 lb.in 0.5 N.m

## Body Weld Studs

- M5: 15.6 lb.in (MAX) 1.75 N.m (MAX)
- M6 & ¼ Inch: 26.4 lb.in (MAX) 3.00 N.m (MAX)

\* External acrylic viewports are susceptible to cracking around the corners if over-torqued. To meet enclosure IP rating requirements and prevent damage to the viewport, follow these torque specifications.

**Note:** The maximum torque suggested for your application is to prevent over-compression of the gasket which may damage the material and compromise the seal of the enclosure. If you are unsure of the torque you are applying to a fastener, bolt down until the gasket begins to expand from under the head of the fastener then back off one eighth turn.

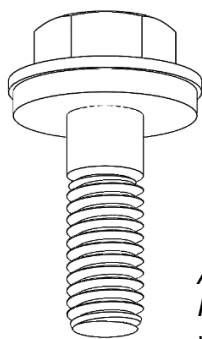

*APG Custom  
Flanged-Hex Head  
with Gasket*

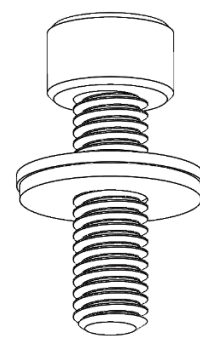

*Fastener with  
Bonded Sealing  
Washer Gasket*

# Cable Gland Instruction

To correctly use the **Cable Gland**, determine the diameter(s) of the cable(s) you want to run into the enclosure. Select an end drill (best) or drill bit of the **same** diameter or up to **20 thousandths larger**. See the next page for protection level based on hole diameter versus cable diameter. While the **Cable Gland** is assembled, mill or drill a hole for each cable centered on the split line in the **Split Insert**.

**Note:** To get the cleanest hole, do the following:

1. Use an end mill.
2. Mill from the Crown Nut side.
3. When milling the hole, back out and clean the mill flutes frequently (every 1/4" depth).
4. Chill down the end mill before milling each hole.

To install the cable(s), unscrew the **Crown Nut** and remove the **Split Insert**. Slide the cable connector through the hole in the **Crown Nut**, then through the hole in the **Cable Gland** body. Join the two sides of the **Split Insert** around the cable and press the **Split Insert** back into the **Cable Gland** body. Tighten the **Crown Nut** back on the body.

And you are finished! You should now have a liquid tight seal around the cable without having to remove or replace the cable connector.

**Note:** For bulkhead installations, drill or punch the following mounting hole sizes:

PG16: 23.5mm (0.93") *Can use a 15/16" drill*

PG21: 29.3mm (1.15") *Can use a 1 3/16" drill*

PG29: 38.0mm (1.50") *Can use a 1 1/2" drill*

PG36: 48.0mm (1.89") *Can use a 1 15/16" drill*

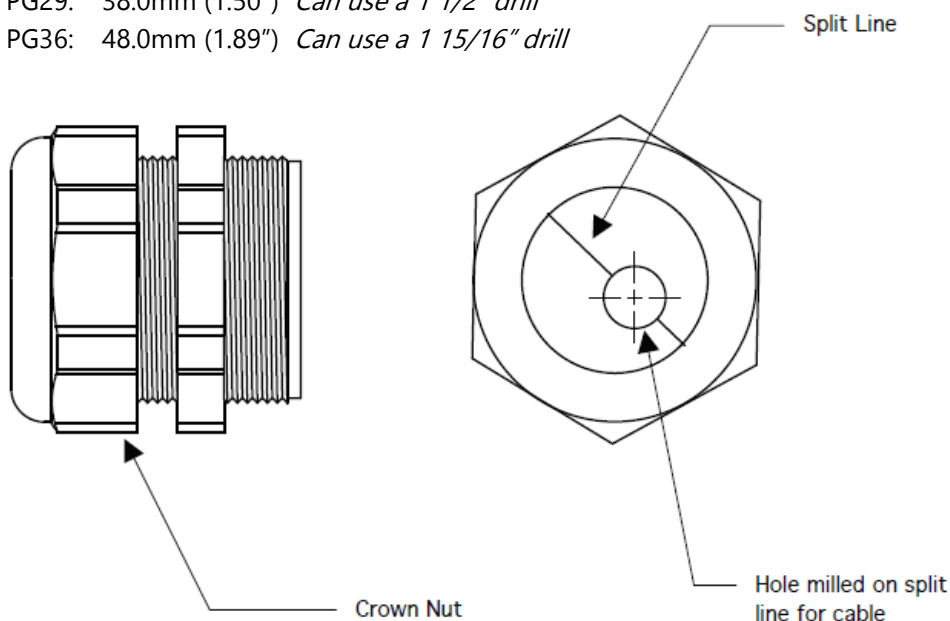

**Note:**

When cutting holes in the PG16 Split Insert, an end mill is recommended. Drills work poorly in this size.

# Replacement/Addition Cable Glands

PG16, PG21, PG29, and PG36 cable glands are available separately for running your cables through bulkheads, enclosure sides, etc.

## Standard Series (All cable glands are RoHS compliant)

Part Number	Description
PG16-01-01-01-01	PG16 Lock Ring, Polycarbonate Body/Crown Nut, TPE Insert, Polyethylene Seal
PG21-01-01-01-01	PG21 Lock Ring, Polycarbonate Body/Crown Nut, TPE Insert, Polyethylene Seal
PG29-01-01-01-01	PG29 Lock Ring, Polycarbonate Body/Crown Nut, TPE Insert, Polyethylene Seal
PG36-01-01-01-01	PG36 Lock Ring, Polycarbonate Body/Crown Nut, TPE Insert, Polyethylene Seal

Protection Rating: IP68; NEMA 4X

If Cable Diameter = Insert Hole Diameter

Protection Rating: IP65; NEMA 3

If Cable Diameter is up to 10% less than Insert Hole Diameter

## Torque Recommendations      lbf-in. (Nm)

The listed torque values are for reference only. Due to wide range of cable insulation materials used and the varying degrees of hardness between material types, torque values for Dome Nuts may vary depending on the cable jacket's characteristics. APG recommends that applied torques be determined empirically by testing the actual cable and Cord Grip used.

External Thread Size	Non-Metallic Cord Grip		Metallic Cord Grip
	Dome Nut	External Thread/Lock Nut	Dome Nut
PG16	44.0 (5.0)	44.0 (5.0)	66.0 (7.5)
PG21	66.0 (7.5)	66.0 (7.5)	88.0 (10.0)
PG29	66.0 (7.5)	66.0 (7.5)	88.0 (10.0)
PG36	66.0 (7.5)	66.0 (7.5)	88.0 (10.0)

