



Industrial Enclosures for:

- Cameras • Lighting
- Pan & Tilt Mounts
- Custom Applications



Industrial Enclosures for Harsh Environments

User Manual
Series L7, L10

Allison Park Group, Inc.
4055 Alpha Drive, Allison Park, PA 15101
www.apgvision.com
412.487.8211

Introduction

Developed and tested by APG Inc., this enclosure was designed to protect your device(s) in harsh, industrial environments. Follow this guide for instructions on assembling and maintaining the enclosure while ensuring the performance of the integrated component.

Protection Rating

For added protection and to meet FDA/Food-Grade standards, our **L7 and L10 Series** enclosures are rated **NEMA 6 / IP68**, guaranteed to be dust tight as well as protecting against continuous liquid immersion. L7 and L10 Series enclosures are constructed and fastened with Corrosion-Resistant 316 Stainless Steel.

All gaskets are made from a silicone rubber, Viton™ rubber, or EPDM foam. The viewport window may be a clear acrylic with a scratch-resistant coating applied to either side, glass, or clear polycarbonate.

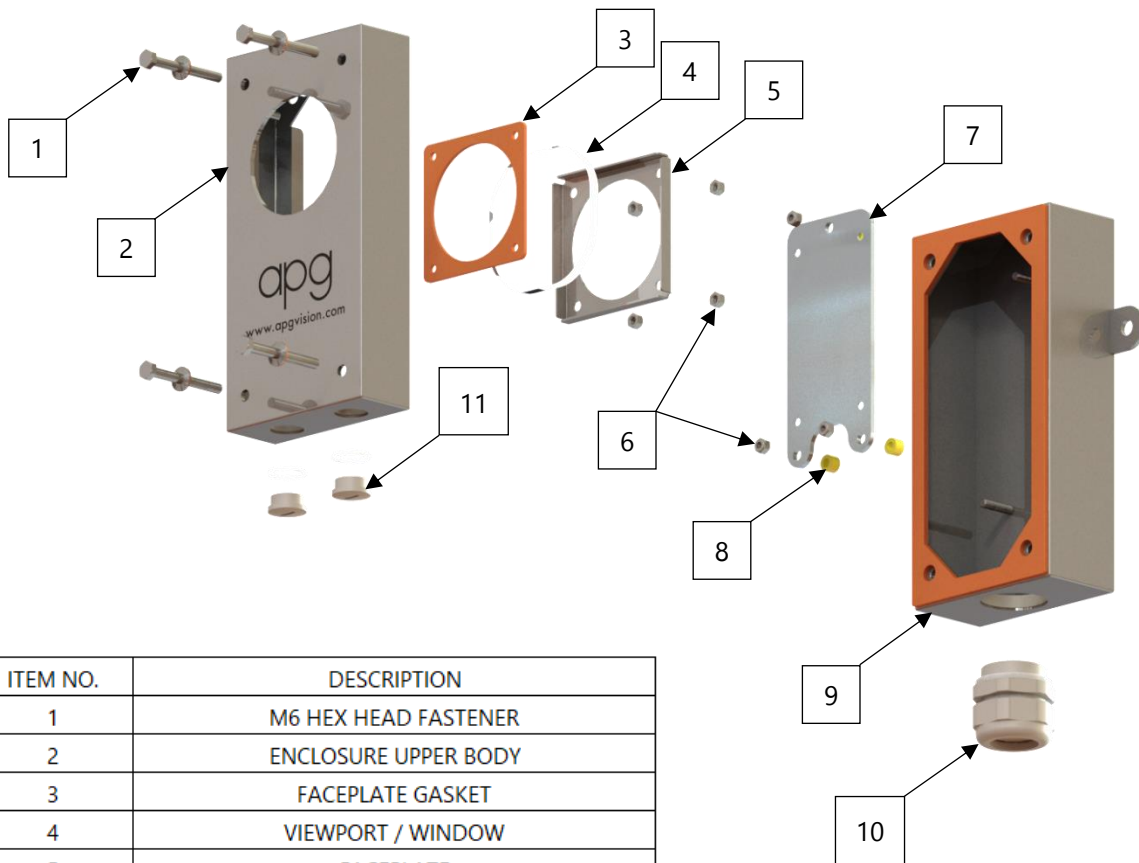

ITEM NO.	DESCRIPTION
1	M6 HEX HEAD FASTENER
2	ENCLOSURE UPPER BODY
3	FACEPLATE GASKET
4	VIEWPORT / WINDOW
5	FACEPLATE
6	M5 HEX NUT
7	MOUNTING BRACKET
8	STANDOFF SPACER
9	ENCLOSURE LOWER BODY
10	CORD GRIP
11	PG11 PLUG

Installation Instructions

1. You may need the following tools:
 - a. 8mm Socket for M5 Hex Nut
 - b. 10mm Socket for M6 Hex Head
 - c. 22mm Socket for PG11 Cord Grip
 - d. Adjustable Wrench
 - e. Wide-Blade Screwdriver
2. Preparing the enclosure:
 - a. Loosen the four (4) M6 hex head fasteners on the front face of the enclosure
 - b. Lift the Enclosure Upper Body away from the Enclosure Lower Body.

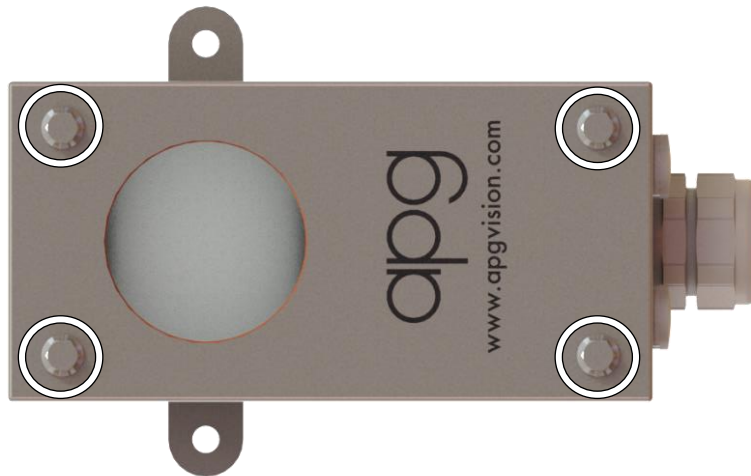

3. Mounting the enclosure:
 - a. Two (2) 9mm holes are available on the Enclosure Lower Body for mounting.
 - b. Note that the mounting holes are aligned with the viewing axis of the camera.

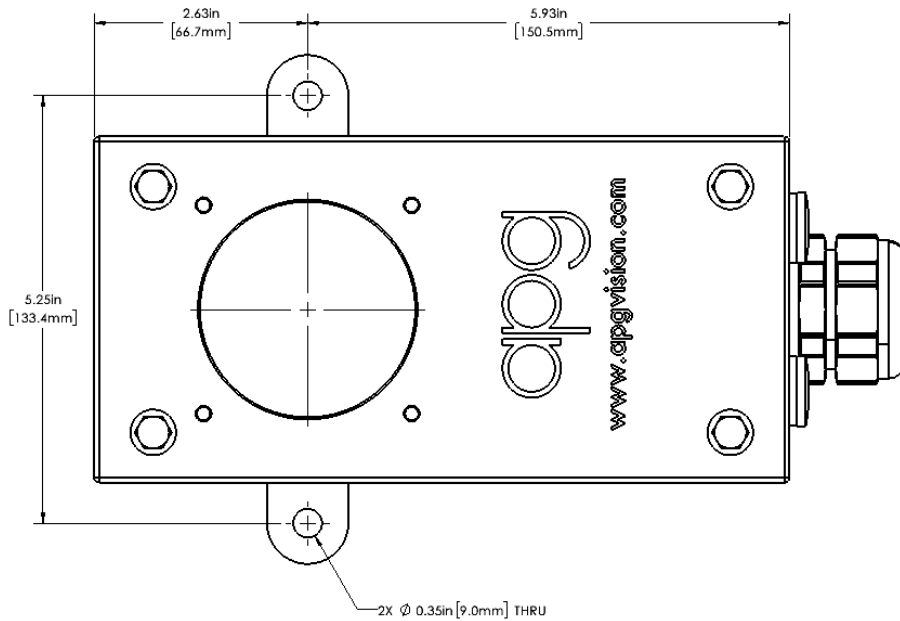

4. Installing your component(s) into the enclosure:
 - a. Remove the three (3) M5 hex nuts securing the bracket to the inside of the enclosure.
 - b. Secure your device to the mounting bracket using the fasteners provided with your device or the optional bolts included with the enclosure.
 - c. By adding or removing spacers between the enclosure case and the mounting bracket you will adjust the distance from the viewport (preventing glare / reflections).
 - d. With your device fastened to the mounting bracket, align the bracket with the threaded studs and secure with the nuts removed in Step 4a.

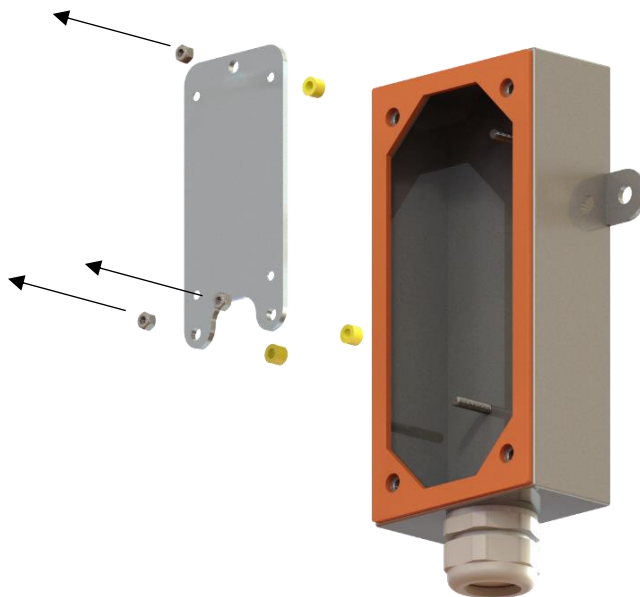

5. Refer to the Cable Gland Instructions at the end of this manual for proper milling of Cable Gland Insert and cable(s) installation.

6. Sealing the enclosure:
 - a. With your component(s) installed in the enclosure, reinstall the Enclosure Upper Body using the bolts removed in Step 2.
 - b. Reference the provided APG Fastener Torque Specifications document to prevent damage to your enclosure and to meet an IP68 rating.

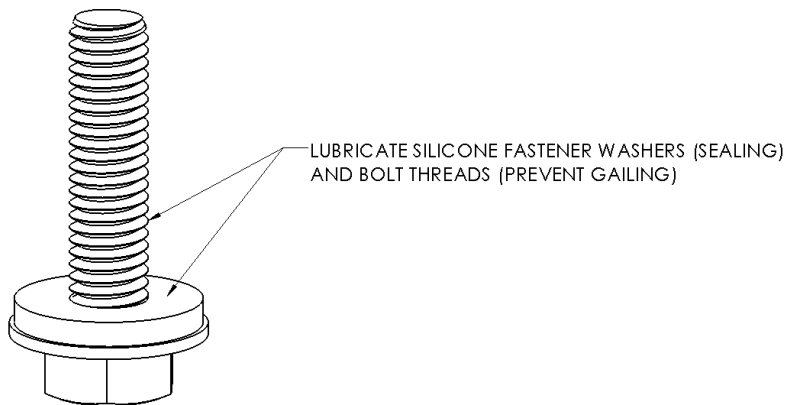
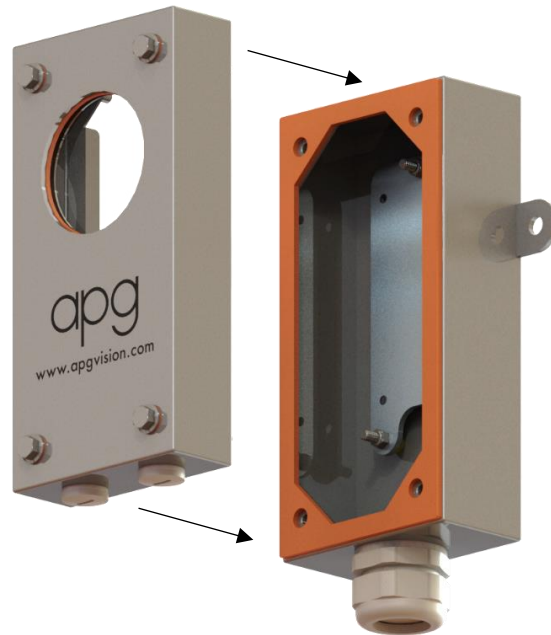

Air-Cooling the Enclosure

This assembly option includes adapters and gaskets to allow your enclosure to be cooled with supplied air.

1. Repeat Step 2 from the Installation Instructions to open your enclosure.

Note: If you are not installing the optional Air Curtain feature, skip to Step 6 of this section.

2. Remove the four (4) M5 hex nuts that are securing the faceplate to the Enclosure Upper Body.
3. Remove the faceplate from the threaded studs, then the viewport, and place on a scratch-free surface.
4. Remove the existing gasket from the threaded studs and replace with the Air Curtain Gasket included with this kit.
5. Replace the viewport, faceplate, and hex nuts removed in Steps 2 and 3 of this section.
 - a. Reference the provided APG Fastener Torque Specifications document to prevent damage to your viewport and to meet an IP68 rating.



Note: With an Air Curtain Gasket the enclosure will become unsealed. If maintaining the seal and air blow-off is desired, ask our sales team about an External Air Curtain.

6. Remove the PG11 Plugs that came installed on the bottom of the Enclosure Upper Body.
 - a. A wide blade screwdriver may be useful to loosen the plugs.
7. Using a 22mm socket and an adjustable wrench, install one or both PG11 > 1/4" NPT adapters into the holes as necessary.
8. Recommended supply air pressure is **2-5 PSIA (0.138-0.345 Bar)**.
 - a. Make sure air is clean and dry. Long air lines can accumulate moisture in humid environments.



Cleaning and Maintenance

Stainless Steel:

When cleaning the stainless-steel body of your enclosure be sure to avoid bleach and cleaners with chlorine as these will stain and damage the surface. Additionally, steel wool and brushes should be avoided to preserve the polished finish.

Aluminum:

Anodized aluminum parts may require abrasive cleaning with gentle cleaning products such as soap and water. Harsh cleaning products may react with unfinished aluminum parts.

Acrylic / Polycarbonate:

Although your acrylic window comes with an anti-abrasion coating, it is important to routinely clean the surface to maintain visibility. APG recommends a plastic/acrylic cleaning solution, otherwise use soap and water with a microfiber towel.

DO NOT use ammonia, acetone, or alcohol-based cleaners; this will crack and weaken the acrylic.

Glass:

It is important to routinely clean the surface of your enclosure's window to maintain visibility. For glass, make sure the surface is wet before cleaning to avoid scratching the surface. A microfiber towel is recommended for wiping down the surface when you are finished washing.

Temperature Tolerance

The listed temperature ranges are for reference only. Exceeding these values may result in compromising the liquid tight enclosure and permanently damaging the material. Stainless Steel and Nickel-plated Brass Cable Gland Bodies are available if your application exceeds these materials' tolerances.

Polyethylene: -4° to 200° F
EPDM Foam: -40° to 250° F
Polycarbonate: -4° to 285° F
TPE Split Insert: -20° to 285° F
Viton™ Rubber: -20° to 400° F
Silicone: -100° to 400° F

Additional Included Parts

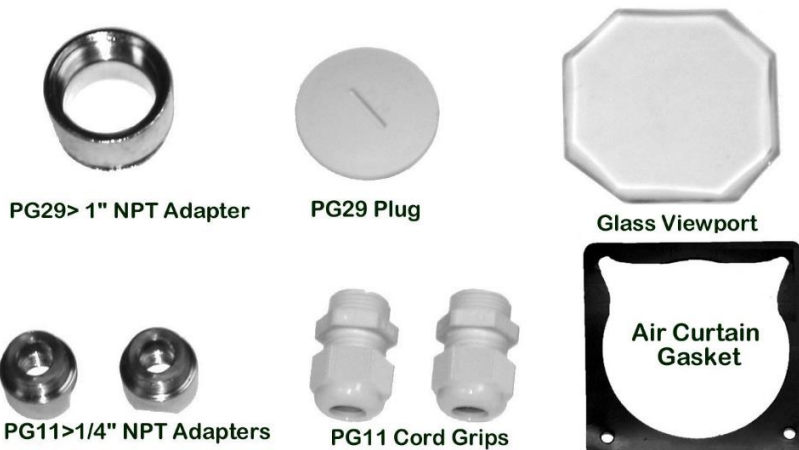

Warranty Statement

Allison Park Group, Inc. (APG) warrants the equipment manufactured by it to be free from defects in materials and workmanship under normal use and service; its obligation under this warranty being limited to replacing at its facility any product, part, or parts which shall, within one (1) year after delivery of such equipment to the original purchaser, be returned, and which APG's examination shall disclose at its sole discretion to have been defective. This one (1) year warranty is forfeited by tampering, modifying, or altering the APG product in any way that is beyond the scope of provided instructions for routine inspection, care, and installation of integrated components. APG expressly disclaims any express or implied warranty of merchantability or fitness for a particular purpose. APG shall have no liability for damages, direct or consequential, on account of defective materials or workmanship. APG reserves the right to make changes in design, or to make additions to, or improvements in, its products without imposing any obligation upon itself to install them on its products previously installed. APG may provide assistance in the form of recommendations, engineering or technical information, and advice but such information is furnished only as an accommodation and APG shall have no liability for incomplete, faulty, or inaccurate advice, recommendations, or assistance, negligent or otherwise. APG accepts responsibility for the warranty of integrated components that are purchased and installed at its facility, subject to their terms and limitations. Returns or replacements of parts and/or products may be subject to shipping, handling, replacement, and/or restocking fees. Some regions do not allow limitations on how long an implied warranty lasts or allow exclusion or limitation of incidental or consequential damages, so the above limitations or exclusions may not apply to you. This warranty gives you specific legal rights, and you may also have other rights, which vary region to region.

Fastener Torque Specifications

To properly fasten components of our enclosures, determine the fastener size (M5 or M6, typically) and the material of the gasket being compressed (Silicone, EDPM Foam, or Viton). Lubrication is applied to all tapped threads during assembly and reapplication is suggested if component is being reassembled.

M5 Fasteners

- Silicone Gasket: 6.0 lb.in 0.6 N.m
- EDPM Foam Gasket: 4.0 lb.in 0.5 N.m
- Viton Gasket: 8.0 lb.in 0.9 N.m

M6 and ¼ Inch Fasteners

- Silicone Gasket: 8.0 lb.in 0.9 N.m
- EDPM Foam Gasket: 4.0 lb.in 0.5 N.m
- Viton Gasket: 10.0 lb.in 1.1 N.m

External Acrylic Viewport *

- Silicone Gasket: 4.0 lb.in 0.5 N.m
- EDPM Foam Gasket: 4.0 lb.in 0.5 N.m
- Viton Gasket: 4.0 lb.in 0.5 N.m

Body Weld Studs

- M5: 15.6 lb.in (MAX) 1.75 N.m (MAX)
- M6 & ¼ Inch: 26.4 lb.in (MAX) 3.00 N.m (MAX)

* External acrylic viewports are susceptible to cracking around the corners if over-torqued. To meet enclosure IP rating requirements and prevent damage to the viewport, follow these torque specifications.

Note: The maximum torque suggested for your application is to prevent over-compression of the gasket which may damage the material and compromise the seal of the enclosure. If you are unsure of the torque you are applying to a fastener, bolt down until the gasket begins to expand from under the head of the fastener then back off one eighth turn.

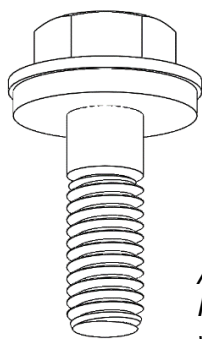

*APG Custom
Flanged-Hex Head
with Gasket*

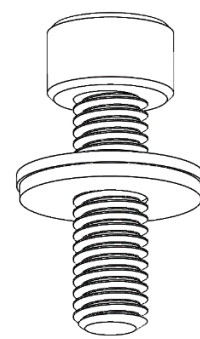

*Fastener with
Bonded Sealing
Washer Gasket*

Cable Gland Instruction

To correctly use the **Cable Gland**, determine the diameter(s) of the cable(s) you want to run into the enclosure. Select an end drill (best) or drill bit of the **same** diameter or up to **20 thousandths larger**. See the next page for protection level based on hole diameter versus cable diameter. While the **Cable Gland** is assembled, mill or drill a hole for each cable centered on the split line in the **Split Insert**.

Note: To get the cleanest hole, do the following:

1. Use an end mill.
2. Mill from the Crown Nut side.
3. When milling the hole, back out and clean the mill flutes frequently (every 1/4" depth).
4. Chill down the end mill before milling each hole.

To install the cable(s), unscrew the **Crown Nut** and remove the **Split Insert**. Slide the cable connector through the hole in the **Crown Nut**, then through the hole in the **Cable Gland** body. Join the two sides of the **Split Insert** around the cable and press the **Split Insert** back into the **Cable Gland** body. Tighten the **Crown Nut** back on the body.

And you are finished! You should now have a liquid tight seal around the cable without having to remove or replace the cable connector.

Note: For bulkhead installations, drill or punch the following mounting hole sizes:

PG16: 23.5mm (0.93") *Can use a 15/16" drill*

PG21: 29.3mm (1.15") *Can use a 1 3/16" drill*

PG29: 38.0mm (1.50") *Can use a 1 1/2" drill*

PG36: 48.0mm (1.89") *Can use a 1 15/16" drill*

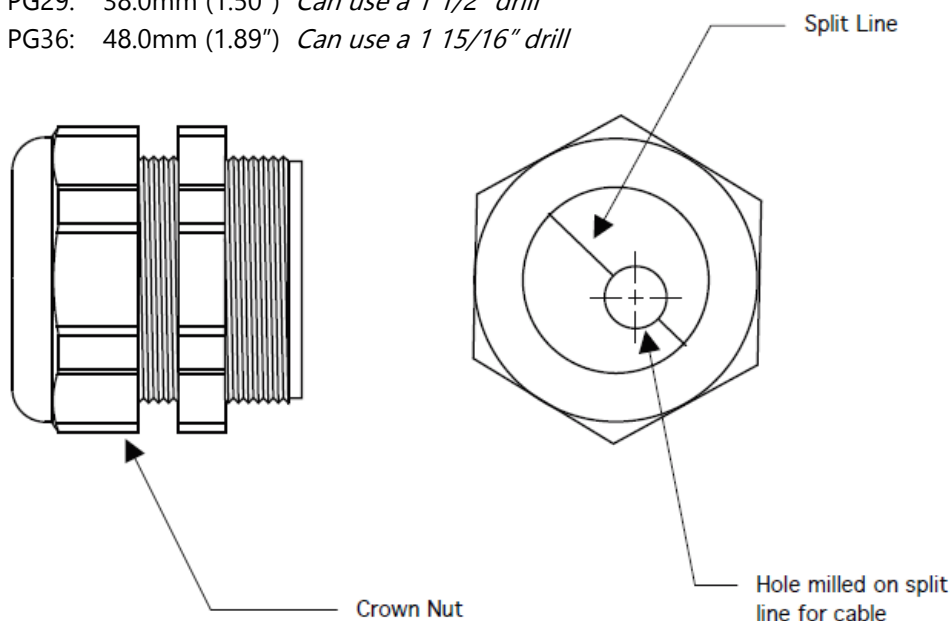

Note:

When cutting holes in the PG16 Split Insert, an end mill is recommended. Drills work poorly in this size.

Replacement/Addition Cable Glands

PG16, PG21, PG29, and PG36 cable glands are available separately for running your cables through bulkheads, enclosure sides, etc.

Standard Series (All cable glands are RoHS compliant)

Part Number	Description
PG16-01-01-01-01	PG16 Lock Ring, Polycarbonate Body/Crown Nut, TPE Insert, Polyethylene Seal
PG21-01-01-01-01	PG21 Lock Ring, Polycarbonate Body/Crown Nut, TPE Insert, Polyethylene Seal
PG29-01-01-01-01	PG29 Lock Ring, Polycarbonate Body/Crown Nut, TPE Insert, Polyethylene Seal
PG36-01-01-01-01	PG36 Lock Ring, Polycarbonate Body/Crown Nut, TPE Insert, Polyethylene Seal

Protection Rating: IP68; NEMA 4X

If Cable Diameter = Insert Hole Diameter

Protection Rating: IP65; NEMA 3

If Cable Diameter is up to 10% less than Insert Hole Diameter

Torque Recommendations lbf-in. (Nm)

The listed torque values are for reference only. Due to wide range of cable insulation materials used and the varying degrees of hardness between material types, torque values for Dome Nuts may vary depending on the cable jacket's characteristics. APG recommends that applied torques be determined empirically by testing the actual cable and Cord Grip used.

External Thread Size	Non-Metallic Cord Grip		Metallic Cord Grip
	Dome Nut	External Thread/Lock Nut	Dome Nut
PG16	44.0 (5.0)	44.0 (5.0)	66.0 (7.5)
PG21	66.0 (7.5)	66.0 (7.5)	88.0 (10.0)
PG29	66.0 (7.5)	66.0 (7.5)	88.0 (10.0)
PG36	66.0 (7.5)	66.0 (7.5)	88.0 (10.0)

